

Duct Sensor CO₂ / Temperature

Active sensor (0...10 V) for measuring CO₂ or with integrated temperature sensor. See options below for integrated sensors. Dual channel CO₂ technology. NEMA 4X / IP65 rated enclosure.

Type Overview

Type	Output signal active CO ₂	Output signal active temperature
22DC-11	DC 0...10 V	-
22DTC-11	DC 0...5 V, DC 0...10 V	DC 0...5 V, DC 0...10 V

Technical Data

Electrical data	Power supply DC	15...24 V, ±10%, 1.5 W
	Power supply AC	24 V, , ±10%, 2.9 VA
	Electrical connection	Removable spring loaded terminal block max. 2.5 mm ²
Functional data	Cable entry	Cable gland with strain relief Ø6...8 mm
	Sensor Technology	CO ₂ : NDIR (non dispersive infrared) dual channel
	Output signal active note	Output DC 0...5/10 V with Jumper adjustable Voltage output: min. 10 kΩ load
	Application	Air
Measuring data	Measuring values	CO ₂ Temperature
	Measuring range CO ₂	0...2000 ppm
	Measuring range temperature	0...50°C [30...120°F]
	Accuracy CO ₂	±(50 ppm + 3% of measuring value)
	Accuracy temperature active	±0.5°C @ 21°C [±0.9°F @ 70°F]
Materials	Cable gland	PA6, black
	Housing	Cover: Lexan, orange Bottom: Lexan, orange Seal: 0467 NBR70, black UV resistant
	Probe material	PA6, black

Safety data	Ambient humidity	Max. 95% r.H., non-condensing
	Medium humidity	Max. 95% r.H., non-condensing
	Ambient temperature	0...50°C [30...120°F]
	Fluid temperature	0...50°C [30...120°F]
	Operating condition air flow	min. 0.3 m/s max. 12 m/s
	Protection class IEC/EN	III Safety Extra-Low Voltage (SELV)
	Protection class UL	UL Class 2 Supply
	EU Conformity	CE Marking
	Certification IEC/EN	IEC/EN 60730-1
	Certification UL	cULus acc. to UL60730-1A/-2-9, CAN/CSA E60730-1:02/-2-9
	Degree of protection IEC/EN	IP65
	Quality Standard	ISO 9001

Safety notes

This device has been designed for use in stationary heating, ventilation and air-conditioning systems and must not be used outside the specified field of application. Unauthorised modifications are prohibited. The product must not be used in relation with any equipment that in case of a failure may threaten humans, animals or assets.

Ensure all power is disconnected before installing. Do not connect to live/operating equipment.

Only authorised specialists may carry out installation. All applicable legal or institutional installation regulations must be complied during installation.

The device contains electrical and electronic components and must not be disposed of as household refuse. All locally valid regulations and requirements must be observed.

Remarks

General remarks concerning sensors Sensing devices with a transducer should always be operated in the middle of the measuring range to avoid deviations at the measuring end points. The ambient temperature of transducer electronics should be kept constant. The transducers must be operated at a constant supply voltage (± 0.2 V). When switching the supply voltage on/off, onsite power surges must be avoided.

Build-up of Self-Heating by Electrical Dissipative Power Temperature sensors with electronic components always have a dissipative power which affects the temperature measurement of the ambient air. The dissipation in active temperature sensors shows a linear increase with rising operating voltage. The dissipative power should be taken into account when measuring temperature. In case of a fixed operating voltage (± 0.2 V) this is normally done by adding or reducing a constant offset value. As Belimo transducers work with a variable operating voltage, only one operating voltage can be taken into consideration, for reasons of production engineering. Transducers 0...10 V / 4...20 mA have a standard setting at an operating voltage of DC 24 V. That means, that at this voltage, the expected measuring error of the output signal will be the least. For other operating voltages, the offset error will be increased by a changing power loss of the sensor electronics. If a re-calibration should become necessary later directly on the sensor, this can be done by means of a trimming potentiometer on the sensor board.

Information Self-Calibration Feature CO₂ All CO₂ sensors are subject to drift caused by the aging process of the components, resulting in regular re-calibration or replacement of units. However, the dual channel technology integrates automatic self-calibration technology vs. common used ABC-Logic sensors. Dual channel self-calibration technology is ideally suited for applications operating 24/7 hours such as those in hospitals or other commercial applications. Manual calibration is not required.

Scope of delivery

Scope of delivery	Description	Type
	Mounting flange for duct sensor 19.5 mm, Plastic	A-22D-A35

Accessories

Optional accessories	Description	Type
	Replacement filter, wire mesh, Stainless steel	A-22D-A06
	Connection adapter, M20, for cable 1 x 6 mm, Multipack 10 pcs.	A-22G-A01.1

Wiring diagram

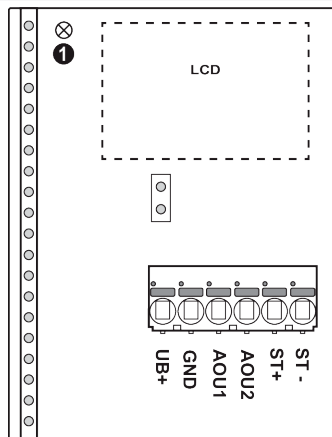
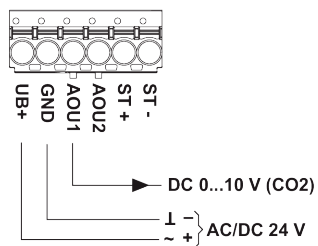

22DC-11 / 22DC-51
 DC 0...10 V

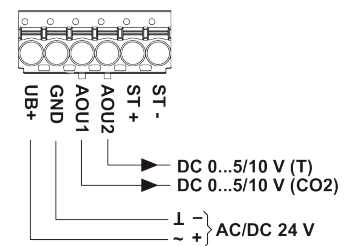
① Status LED

22DTC-11 / 22DTC-51
 2 x DC 0...5/10 V

Dimensions

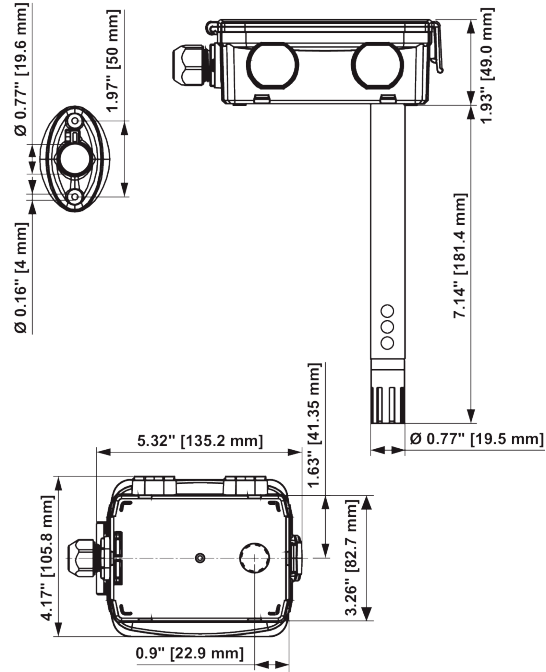
Dimensions



Type	Probe length	Weight
22DC-11	180 mm	0.26 kg
22DTC-11	180 mm	0.28 kg