

Duct Sensor Humidity / Temperature

For measuring the relative or absolute humidity and temperature in duct applications. Instead of the humidity signal, the enthalpy or the dewpoint can be selected as an output signal. With BACnet MS/TP communication and integrated 0 ... 10V outputs. Nema 4X / IP65 rated enclosure.



Type Overview

Type	Output signal	Output signal active temperature	Output signal active humidity
22DTH-16M	BACnet	DC 0...5 V, DC 0...10 V	DC 0...5 V, DC 0...10 V

Technical Data

Electrical data	Power supply DC	15...24 V, $\pm 10\%$, 0.7 W
	Power supply AC	24 V, , $\pm 10\%$, 1.8 VA
Functional data	Electrical connection	Removable spring loaded terminal block max. 2.5 mm ²
	Cable entry	Cable gland with strain relief 2 x Ø6 mm
	Sensor Technology	Polymer capacitive sensor with stainless steel wire mesh filter
	Communicative control	BACnet MS/TP
	Output signal active note	Output DC 0...5/10 V selectable with switch
Measuring data	Application	Air
	Measuring values	Temperature Relative humidity Dew point Enthalpies Absolute humidity
	Measuring range humidity	0...100% r.H. selectable via BACnet
	Measuring range temperature	-35...90°C [-30...195°F] selectable via BACnet Attention: max. measuring temperature is restricted by max. fluid temperature (see Safety data)
	Measuring range absolute humidity	0...80 g/m ³ selectable via BACnet
	Measuring range enthalpy	0...85 kJ/kg selectable via BACnet
	Measuring range dew point	-20...80°C selectable via BACnet
	Accuracy humidity	$\pm 2\%$ between 10...90% r.H. @ 21°C
	Accuracy temperature active	$\pm 0.5^\circ\text{C}$ @ 25°C [$\pm 0.9^\circ\text{F}$ @ 77°F]

Materials	Cable gland	PA6, black
	Housing	Cover: Lexan, orange Bottom: Lexan, orange Seal: 0467 NBR70, black UV resistant
Safety data	Ambient humidity	Max. 95% r.H., non-condensing
	Medium humidity	Short-term condensation permitted
	Ambient temperature	-35...50°C [-30...120°F]
	Fluid temperature	-35...70°C [-30...160°F]
	Operating condition air flow	max. 12 m/s
	Protection class IEC/EN	III Safety Extra-Low Voltage (SELV)
	Protection class UL	UL Class 2 Supply
	EU Conformity	CE Marking
	Certification IEC/EN	IEC/EN 60730-1
	Certification UL	cULus acc. to UL60730-1A/-2-9/-2-13, CAN/CSA E60730-1:02/-2-9
	Degree of protection IEC/EN	IP65
	Degree of protection NEMA/UL	NEMA 4X
	Quality Standard	ISO 9001

Safety notes

This device has been designed for use in stationary heating, ventilation and air-conditioning systems and must not be used outside the specified field of application. Unauthorised modifications are prohibited. The product must not be used in relation with any equipment that in case of a failure may threaten humans, animals or assets. Ensure all power is disconnected before installing. Do not connect to live/operating equipment.

Only authorised specialists may carry out installation. All applicable legal or institutional installation regulations must be complied during installation.

The device contains electrical and electronic components and must not be disposed of as household refuse. All locally valid regulations and requirements must be observed.

Remarks

- General remarks concerning sensors** Sensing devices with a transducer should always be operated in the middle of the measuring range to avoid deviations at the measuring end points. The ambient temperature of transducer electronics should be kept constant. The transducers must be operated at a constant supply voltage (± 0.2 V). When switching the supply voltage on/off, onsite power surges must be avoided.
- Build-up of Self-Heating by Electrical Dissipative Power** Temperature sensors with electronic components always have a dissipative power which affects the temperature measurement of the ambient air. The dissipation in active temperature sensors shows a linear increase with rising operating voltage. The dissipative power should be taken into account when measuring temperature. In case of a fixed operating voltage (± 0.2 V) this is normally done by adding or reducing a constant offset value. As Belimo transducers work with a variable operating voltage, only one operating voltage can be taken into consideration, for reasons of production engineering. Transducers 0...10 V / 4...20 mA have a standard setting at an operating voltage of DC 24 V. That means, that at this voltage, the expected measuring error of the output signal will be the least. For other operating voltages, the offset error will be increased by a changing power loss of the sensor electronics. If a re-calibration should become necessary later directly on the sensor, this can be done by means of a trimming potentiometer on the sensor board.
- Application Notice for Humidity Sensors** Refrain from touching the sensitive humidity sensor/element. Touching the sensitive surface will void warranty.
- For standard environmental conditions the manufacturing accuracy specified in the datasheet will be covered by the calibration warranty for two years. When exposed to harsh environmental conditions such as high ambient temperature and/or high levels of humidity, or presence of aggressive gases (i.e. chlorine, ozone, ammonia) the sensor element may be affected and readings may be outside specified accuracy. Replacement of deteriorated humidity sensors due to harsh environmental conditions are not subject of the general warranty.

Scope of delivery

Scope of delivery	Description	Type
	Mounting flange for duct sensor 19.5 mm, Plastic	A-22D-A35
	Cable Gland with strain relief $\varnothing 6...8$ mm	

Accessories

Optional accessories	Description	Type
	Replacement filter, wire mesh, Stainless steel	A-22D-A06
	Connection adapter, M20, for cable 1 x 6 mm, Multipack 10 pcs.	A-22G-A01.1
	Connection adapter, M20, for cable 2 x 6 mm, Multipack 10 pcs.	A-22G-A02.1

Wiring diagram

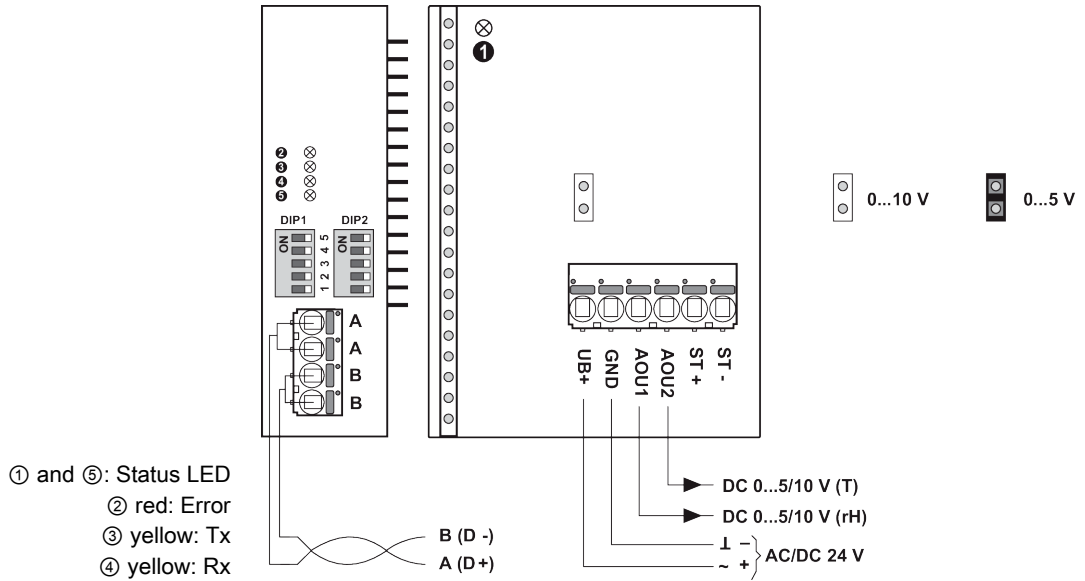

Connectors ST+ / ST- are only used for sensor types which additionally have a passive resistance sensor element for temperature measurement.

The adjustment of the measuring ranges is made by changing the bonding jumpers. The output value in the new measuring range is available after 2 seconds.

Detailed documentation

The separate document, BACnet PICS, informs about the PICS, MAC addressing and bus termination (DIP1 & DIP2).

Notes Wiring RS485



Connection via safety isolating transformer.

Parallel connection of other devices possible. Observe the performance data.

The wiring of the line for BACnet MS/TP / Modbus RTU is to be carried out in accordance with applicable RS485 regulations.

Wiring RS485 (Modbus RTU & BACnet MS/TP)

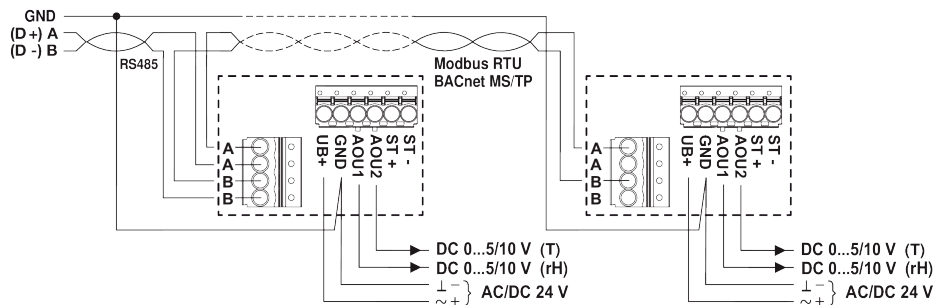

Dimensions

Dimensions

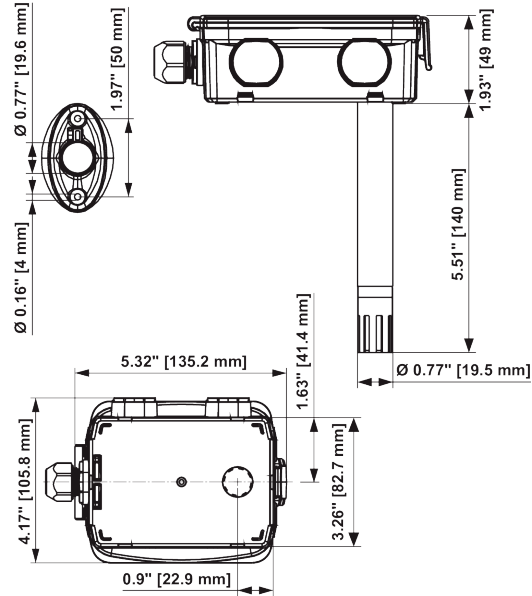

Type	Probe length	Weight
22DTH-16M	140 mm	0.26 kg