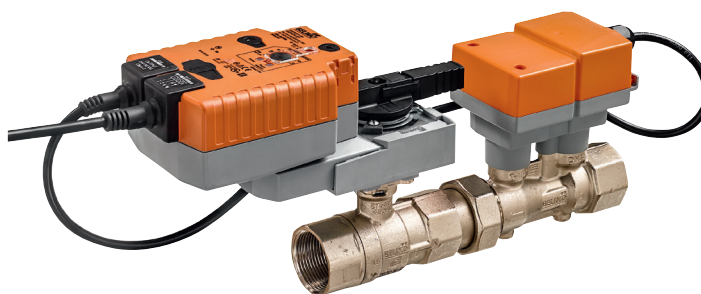

Characterised control valve with sensor-operated flow control with fail-safe, 2-way, internal thread, PN 16 (EPIV)

- Nominal voltage AC/DC 24 V
- Control modulating, communicative
- For closed cold and warm water systems
- For modulating control of air-handling and heating systems on the water side
- Communication via Belimo MP-Bus or conventional control
- Conversion of active sensor signals and switching contacts
- Design life SuperCaps: 15 years

Type overview

Type	DN []	Rp ["]	V'nom [l/s]	V'nom [l/min]	kvs theor. [m³/h]	PN []	n(gl) []
EP015R+KMP	15	1/2	0.35	21	2.9	16	3.2
EP020R+KMP	20	3/4	0.65	39	4.9	16	3.2
EP025R+KMP	25	1	1.15	69	8.6	16	3.2
EP032R+KMP	32	1 1/4	1.8	108	14.2	16	3.2
EP040R+KMP	40	1 1/2	2.5	150	21.3	16	3.2
EP050R+KMP	50	2	4.8	288	32.0	16	3.2

kvs theory: Theoretical kvs value for pressure drop calculation

Technical data

Electrical data	Nominal voltage	AC/DC 24 V
	Nominal voltage frequency	50/60 Hz
	Nominal voltage range	AC 19.2...28.8 V / DC 21.6...28.8 V
	Power consumption in operation	6 W
	Power consumption in rest position	5 W
	Power consumption for wire sizing	12 VA
	Connection supply / control	Cable 1 m, 4 x 0.75 mm ²
	Parallel operation	Yes (note the performance data)
Functional data	Torque Motor	20 Nm
	Operating range Y	DC 2...10 V
	Input Impedance	100 kΩ
	Operating range Y variable	Start point DC 0.5...24 V End point DC 8.5...32 V
	Options positioning signal	Modulating (DC 0...32 V)
	Position feedback U	DC 2...10 V
	Position feedback U note	Max. 1 mA
	Position feedback U variable	Start point DC 0.5...8 V End point DC 2...10 V
	Setting fail-safe position	NC/NO or adjustable 0...100% (POP rotary knob)
	Bridging time (PF) variable	1...10 s
	Running time fail-safe	35 s / 90°
	Sound power level Motor	45 dB(A)
	Sound power level, fail-safe	61 dB(A)
	Adjustable flow rate V'max	30...100% of Vnom
	Control accuracy	±10% (of 25...100% V'nom)
	Control accuracy note	±6% (of 25...100% Vnom) @ 20°C / Glycol 0% vol.
	Media	Cold and warm water, water with glycol up to max. 50% vol.
	Medium temperature	-10...120°C
	Permissible pressure ps	1600 kPa
	Close-off pressure Δps	1400 kPa
Differential pressure Δpmax	350 kPa	
Differential pressure note	200 kPa for low-noise operation	

Technical data

Functional data	Flow characteristic	equal percentage (VDI/VDE 2178), optimised in the opening range (switchable to linear)
	Leakage rate	air-bubble tight, leakage rate A (EN 12266-1)
	Pipe connectors	Internal thread according to ISO 7-1
	Installation position	upright to horizontal (in relation to the stem)
	Servicing	maintenance-free
	Manual override	with push-button
Flow measurement	Measuring principle	Ultrasonic volumetric flow measurement
	Measuring accuracy flow	±6% (of 25...100% V'nom)
	Measuring accuracy flow note	±2% (of 25...100% Vnom) @ 20 °C / Glycol 0% vol.
	Min. flow measurement	1% of V'nom
Safety	Protection class IEC/EN	III Safety Extra-Low Voltage (SELV)
	Degree of protection IEC/EN	IP54
	EMC	CE according to 2014/30/EU
	Mode of operation	Type 1.AA
	Rated impulse voltage supply / control	0.8 kV
	Control pollution degree	3
	Ambient temperature	-30...50 °C
	Storage temperature	-40...80 °C
	Ambient humidity	Max. 95% r.H., non-condensing
	Materials	Flow measuring pipe
Closing element		Stainless steel
Stem seal		EPDM O-ring
Terms	Abbreviations	POP = Power off position / fail-safe position PF = Power fail delay time / bridging time

Safety notes



- This device has been designed for use in stationary heating, ventilation and air-conditioning systems and must not be used outside the specified field of application, especially in aircraft or in any other airborne means of transport.
- Outdoor application: only possible in case that no (sea) water, snow, ice, insolation or aggressive gases interfere directly with the actuator and that is ensured that the ambient conditions remain at any time within the thresholds according to the data sheet.
- Only authorised specialists may carry out installation. All applicable legal or institutional installation regulations must be complied during installation.
- The device contains electrical and electronic components and must not be disposed of as household refuse. All locally valid regulations and requirements must be observed.

Product features

Mode of operation The final controlling device is comprised of three components: characterised control valve (CCV), measuring pipe with volumetric flow sensor and the actuator itself. The adjusted maximum flow (V'max) is assigned to the maximum positioning signal (typically 10 V / 100%). The final controlling device can be controlled communicative or analogue. The medium is detected by the sensor in the measuring pipe and is applied as the flow value. The measured value is balanced with the setpoint. The actuator corrects the deviation by changing the valve position. The angle of rotation α varies according to the differential pressure through the final controlling element (see volumetric flow curves).
 With the supply voltage the integrated condensers will be charged. Interrupting the supply voltage causes the valve to be moved to the selected fail-safe position by means of stored electrical energy.

Flow characteristic

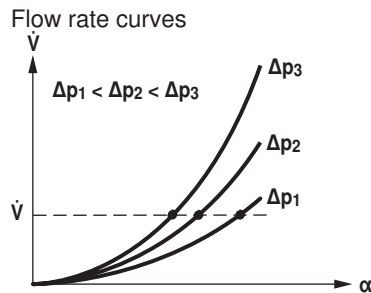

Pre-charging time (start up) The capacitor actuators require a pre-charging time. This time is used for charging the capacitors up to a usable voltage level. This ensures that, in the event of a power failure, the actuator can move at any time from its current position into the preset fail-safe position.

The duration of the pre-charging time depends mainly on following factors:

- Duration of the power failure
- PF delay time (bridging time)

Typical pre-charging time

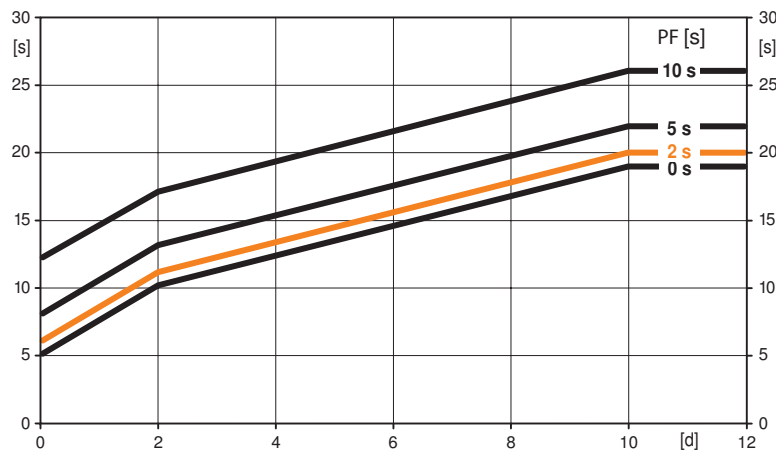

PF [s]	[d]				
	0	1	2	7	≥10
0	5	8	10	15	19
2	6	9	11	16	20
5	8	11	13	18	22
10	12	15	17	22	26

[d] = Electricity interruption in days
 [s] = Pre-charging time in seconds
 PF[s] = Bridging time

Calculation example: Given an electricity interruption of 3 days and a bridging time (PF) set at 5 s, the actuator requires a pre-charging time of 14 s after the electricity has been reconnected (see graphic).

Delivery condition (capacitors)

The actuator is completely discharged after delivery from the factory, which is why the actuator requires approximately 20 s pre-charging time before initial commissioning in order to bring the capacitors up to the required voltage level.

Product features

Setting fail-safe position (POP) The «fail-safe position» rotary knob can be used to adjust the desired fail-safe position 0...100% in 10% increments. The rotary knob always refers to the adapted angle of rotation range. In the event of a power failure, the actuator will move into the selected fail-safe position.

Settings: The rotary knob must be set to the «Tool» position for retroactive settings of the fail-safe position with the Belimo service tool MFT-P. Once the rotary knob is set back to the range 0...100%, the manually set value will have positioning authority.

Bridging time Electrical interruptions can be bridged up to a maximum of 10 s. In the event of a power failure, the actuator will remain stationary in accordance with the set bridging time. If the power failure is greater than the set bridging time, then the actuator will move into the selected fail-safe position .

The bridging time set ex-works is 2 s. This can be modified on site in operation with the use of the Belimo service tool MFT-P.

Settings: The rotary knob must not be set to the «Tool» position!

Only the values need to be entered for retroactive adjustments of the bridging time with the Belimo service tool MFT-P.

Transmission behaviour HE Heat exchanger transmission behaviour

Depending on the construction, temperature spread, medium and hydraulic circuit, the power Q is not proportional to the water volumetric flow \dot{V} (Curve 1). With the classical type of temperature control, an attempt is made to maintain the control signal Y proportional to the power Q (Curve 2). This is achieved by means of an equal-percentage valve characteristic curve (Curve 3).

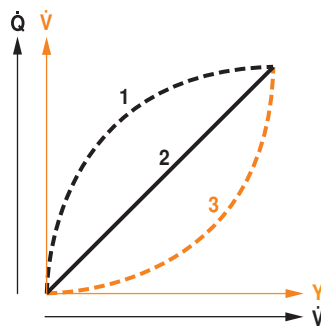

Product features

Control characteristics

The velocity of the medium is measured in the measuring component (sensor electronics) and converted to a flow rate signal. The positioning signal Y corresponds to the power Q via the exchanger, the volumetric flow is regulated in the EPIV. The control signal Y is converted into an equal-percentage characteristic curve and provided with the V'max value as the new reference variable w. The momentary control deviation forms the positioning signal Y1 for the actuator.

The specially configured control parameters in connection with the precise flow rate sensor ensure a stable quality of control. They are however not suitable for rapid control processes, i.e. for domestic water control.

U5 displays the measured volumetric flow as voltage (factory setting). As an alternative, U5 can be used for displaying the valve opening angle. It is always in reference to the respective V'nom, i.e. if V'max is e.g. 50% of V'nom, then Y = 10 V, U5 = 5 V.

1. Standard equal percentage $V_{max} = V_{nom} / 2$. effect $V_{max} < V_{nom}$

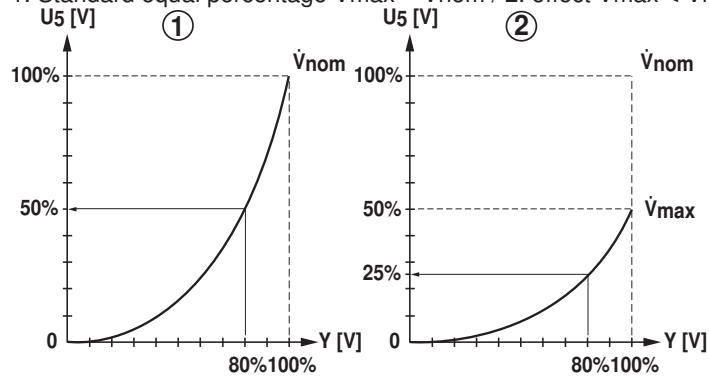

Block diagram

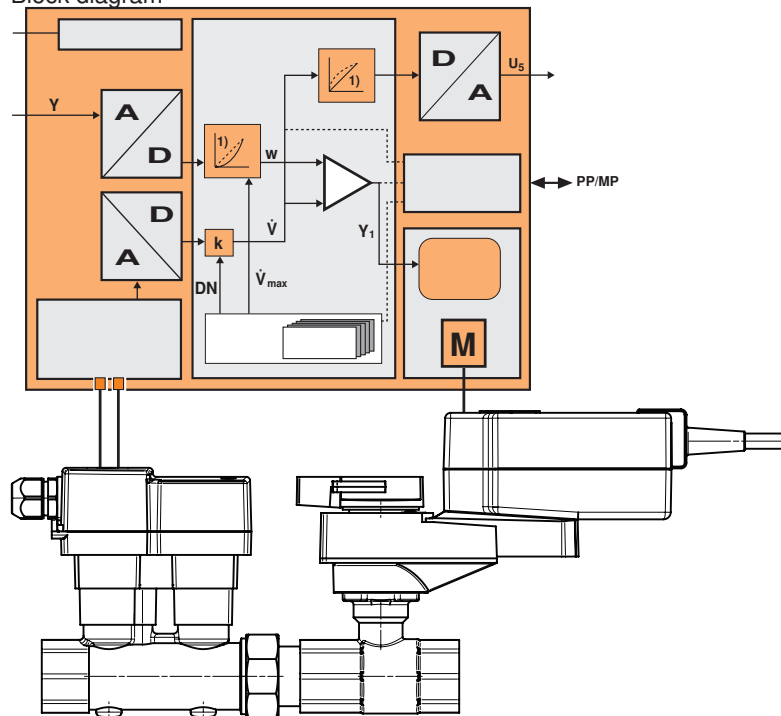

Product features

Definition Flow control
 V'_{nom} is the maximum possible flow.

V'_{max} is the maximum flow rate which has been set with the greatest positioning signal. V'_{max} can be set between 30% and 100% of V'_{nom} .

V'_{min} 0% (non-variable).

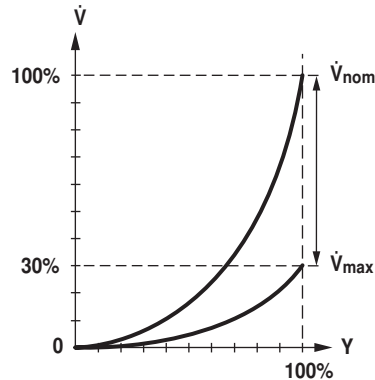

Creep flow suppression Given the very low flow speed in the opening point, this can no longer be measured by the sensor within the required tolerance. This range is overridden electronically.

Opening valve

The valve remains closed until the volumetric flow required by the positioning signal Y corresponds to 1% of V'_{nom} . The control along the valve characteristic curve is active after this value has been exceeded.

Closing valve

The control along the valve characteristic curve is active up to the required flow rate of 1% of V'_{nom} . Once the level falls below this value, the flow rate is maintained at 1% of V'_{nom} . If the level falls below the flow rate of 0.5% of V'_{nom} required by the reference variable Y , then the valve will close.

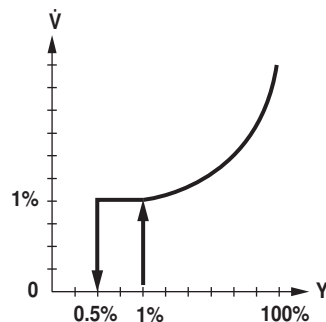

Converter for sensors Connection option for a sensor (active sensor or switching contact). The MP actuator serves as an analogue/digital converter for the transmission of the sensor signal via MP-Bus to the higher level system.

Configurable actuators The factory settings cover the most common applications. Single parameters can be modified with the Belimo Service Tools MFT-P or ZTH EU.

Positioning signal inversion This can be inverted in cases of control with an analogue positioning signal. The inversion causes the reversal of the standard behaviour, i.e. at a positioning signal of 0%, regulation is to V'_{max} , and the valve is closed at a positioning signal of 100%.

Hydraulic balancing With the Belimo tools, the maximum flow rate (equivalent to 100% requirement) can be adjusted on-site, simply and reliably, in a few steps. If the device is integrated in the management system, then the balancing can be handled directly by the management system.

Manual override Manual control with push-button possible - temporary. The gear is disengaged and the actuator decoupled for as long as the button is pressed.

High functional reliability The actuator is overload protected, requires no limit switches and automatically stops when the end stop is reached.

Accessories

	Description	Type
Gateways	Gateway MP zu BACnet MS/TP	UK24BAC
	Gateway MP to Modbus RTU	UK24MOD
	Gateway MP to LonWorks	UK24LON
	Gateway MP to KNX	UK24EIB
Electrical accessories	Description	Type
	Connection cable 5 m, A: RJ11 6/4, B: 6-pin New Generation for ZTH EU	ZK1-GEN
	Connection cable 5 m, A: RJ11 6/4, B: free wire end for ZTH EU	ZK2-GEN
	Connecting board MP-Bus for wiring boxes EXT-WR-FP20-MP (IP20) and EXT-WR-FP65-MP (IP65)	ZFP2-MP
	MP-Bus power supply for MP actuators	ZN230-24MP
Mechanical accessories	Description	Type
	Pipe connector for ball valve with internal thread DN 15 Rp 1/2"	ZR2315
	Pipe connector for ball valve with internal thread DN 20 Rp 3/4"	ZR2320
	Pipe connector for ball valve with internal thread DN 25 Rp 1"	ZR2325
	Pipe connector for ball valve with internal thread DN 32 Rp 1 1/4"	ZR2332
	Pipe connector for ball valve with internal thread DN 40 Rp 1 1/2"	ZR2340
	Pipe connector for ball valve with internal thread DN 50 Rp 2"	ZR2350
Service Tools	Description	Type
	Service tool, Setting tool with ZIP-USB function	ZTH EU
	Belimo PC-Tool, Software for adjustments and diagnostics	MFT-P
	Adapter for Service-Tool ZTH	MFT-C
	Level converter USB/MP	ZIP-USB-MP

Electrical installation

Notes

- Connection via safety isolating transformer.
- Parallel connection of other actuators possible. Observe the performance data.

Wiring diagrams

AC/DC 24 V, modulating

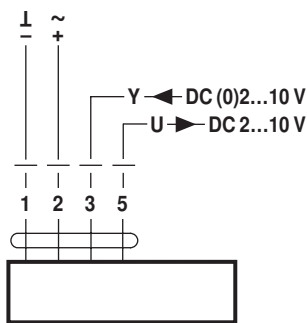

Cable colours:
 1 = black
 2 = red
 3 = white
 5 = orange

Operation on the MP-Bus

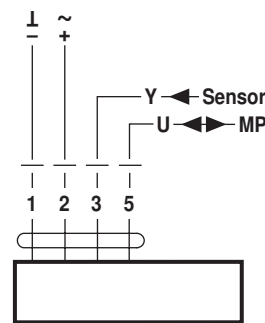

Cable colours:
 1 = black
 2 = red
 3 = white
 5 = orange

Functions

Functions when operated on MP-Bus

Connection on the MP-Bus

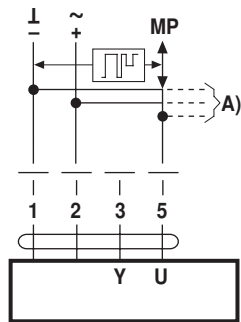

A) more actuators and sensors (max.8)

Network topology

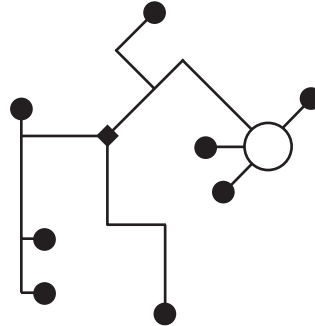

There are no restrictions for the network topology (star, ring, tree or mixed forms are permitted). Supply and communication in one and the same 3-wire cable

- no shielding or twisting necessary
- no terminating resistors required

Connection of active sensors

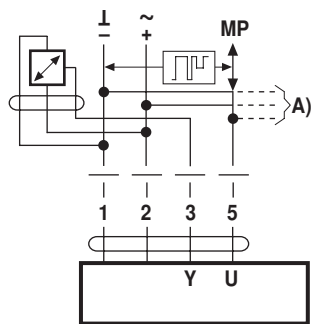

A) more actuators and sensors (max.8)

- Supply AC/DC 24 V
- Output signal DC 0...10 V (max. DC 0...32 V)
- Resolution 30 mV

Connection of external switching contact

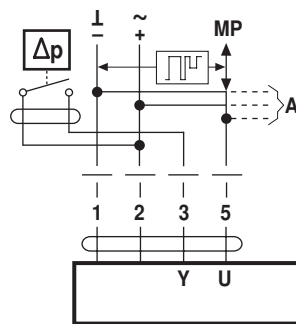

A) more actuators and sensors (max.8)

- Switching current 16 mA @ 24 V
- Start point of the operating range must be parameterised on the MP actuator as ≥ 0.5 V

Functions for actuators with specific parameters (Configuration necessary)

Override control and limiting with AC 24 V with relay contacts

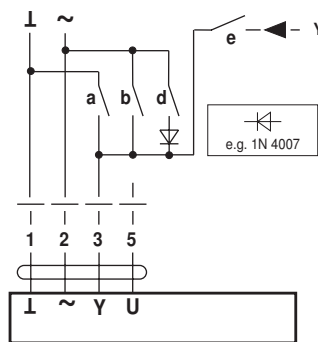

	a	b	d	e
Close				
V _{max}				
Open				
Y				

Override control and limiting with DC 24 V with relay contacts

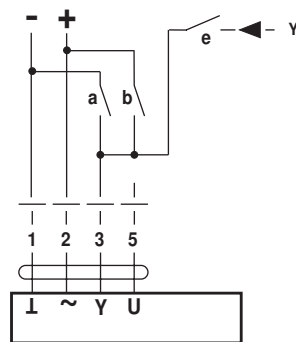

	a	b	d	e
Close				
V _{max}				
Y				

Control 3-point

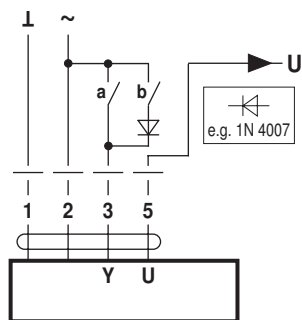

Position control: 90° = 100s
Flow control: V_{max} = 100s

Operating controls and indicators

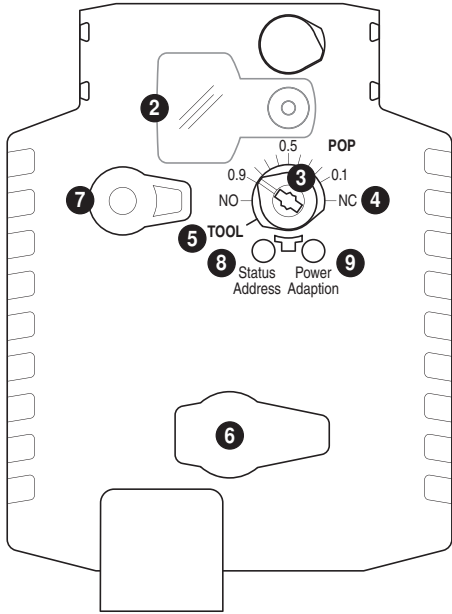

- 2 Cover, POP button
- 3 POP button
- 4 Scale for manual adjustment
- 5 Position for adjustment with tool
- 6 Tool socket
- 7 Disengagement button

LED displays		Meaning / function
8 yellow	9 green	
Off	On	Operation OK / without fault
Off	Flashing	POP function active
On	Off	Fault
Off	Off	Not in operation
On	On	Adaptation procedure running
Flashing	On	Communication

- 8 **Press button:** Acknowledgment of addressing
- 9 **Press button:** Triggers angle of rotation adaption, followed by standard operation
Setting emergency setting position (POP)

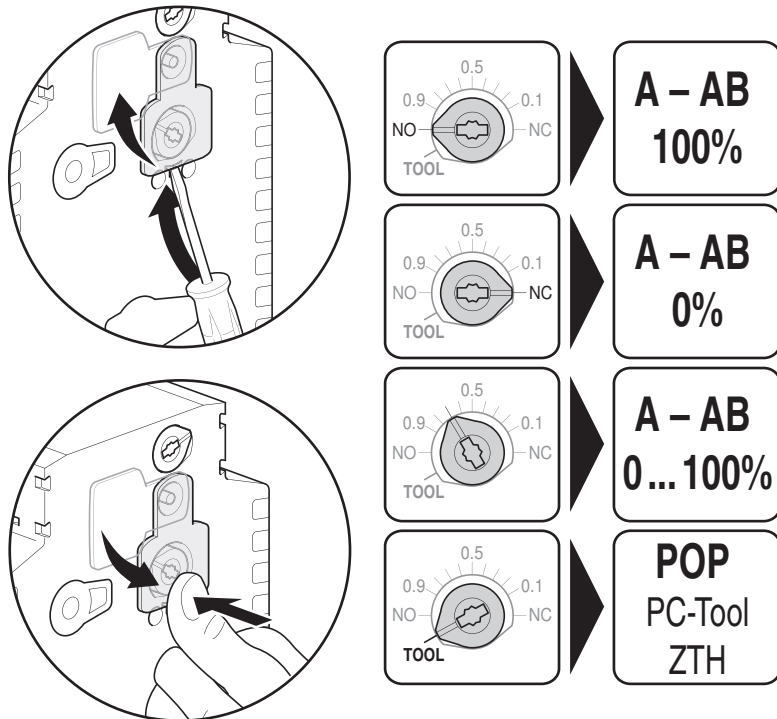

Installation notes

Recommended installation positions The ball valve can be installed upright to horizontal. The ball valve may not be installed in a hanging position, i.e. with the stem pointing downwards.

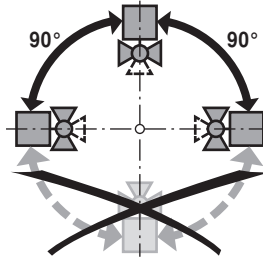

Mounting position in the return Installation in the return is recommended.

Water quality requirements The water quality requirements specified in VDI 2035 must be adhered to. Belimo valves are regulating devices. For the valves to function correctly in the long term, they must be kept free from particle debris (e.g. welding beads during installation work). The installation of a suitable strainer is recommended.

Servicing Ball valves, rotary actuators and sensors are maintenance-free. Before any service work on the final controlling device is carried out, it is essential to isolate the rotary actuator from the power supply (by unplugging the electrical cable if necessary). Any pumps in the part of the piping system concerned must also be switched off and the appropriate slide valves closed (allow all components to cool down first if necessary and always reduce the system pressure to ambient pressure level). The system must not be returned to service until the ball valve and the rotary actuator have been correctly reassembled in accordance with the instructions and the pipeline has been refilled by professionally trained personnel.

Flow direction The direction of flow, specified by an arrow on the housing, is to be complied with, since otherwise the flow rate will be measured incorrectly.

Inlet section In order to achieve the specified measuring accuracy, a flow-calming section or inflow section in the direction of the flow is to be provided upstream from the flow sensor. Its dimensions should be at least 5x DN.

DN	L min.
15	5 x 15 mm = 75 mm
20	5 x 20 mm = 100 mm
25	5 x 25 mm = 125 mm
32	5 x 32 mm = 160 mm
40	5 x 40 mm = 200 mm
50	5 x 50 mm = 250 mm

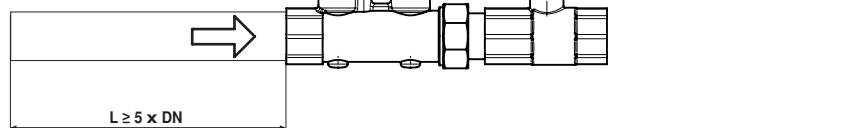

General notes

Valve selection The valve is determined using the maximum required flow rate V'_{max} . A calculation of the kvs value is not required.
 $V'_{max} = 30 \dots 100\%$ of V'_{nom}
 If no hydraulic data are available, then the same valve DN can be selected as the heat exchanger nominal diameter.

General notes

Minimum differential pressure (pressure drop)

The minimum required differential pressure (pressure drop through the valve) for achieving the desired volumetric flow \dot{V}_{max} can be calculated with the aid of the theoretical kvs value (see type overview) and the below-mentioned formula. The calculated value is dependent on the required maximum volumetric flow \dot{V}_{max} . Higher differential pressures are compensated for automatically by the valve.

Formula

$$\Delta p_{min} = 100 \times \left(\frac{\dot{V}_{max}}{k_{vs \text{ theor.}}} \right)^2$$

$\Delta p_{min}: \text{kPa}$
 $\dot{V}_{max}: \text{m}^3/\text{h}$
 $k_{vs \text{ theor.}}: \text{m}^3/\text{h}$

Example (DN25 with the desired maximum flow rate = 50% \dot{V}_{nom})
 EP025R+KMP

kvs theor. = 8.6 m³/h

\dot{V}_{nom} = 69 l/min

50% * 69 l/min = 34.5 l/min = 2.07 m³/h

$$\Delta p_{min} = 100 \times \left(\frac{\dot{V}_{max}}{k_{vs \text{ theor.}}} \right)^2 = 100 \times \left(\frac{2.07 \text{ m}^3/\text{h}}{8.6 \text{ m}^3/\text{h}} \right)^2 = 6 \text{ kPa}$$

Valve selection

In case of a flow sensor error, the EPIV will switch from flow control to position control. Once the error disappears, the EPIV will switch back to the normal control setting.

Service

Service Tools connection

The actuator can be configured by ZTH EU via the service socket. For an extended configuration the PC tool can be connected.

Connection ZTH EU / PC-Tool

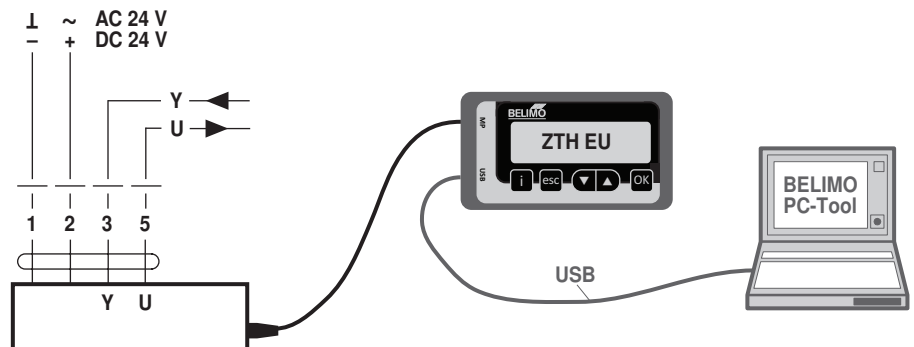

Dimensions / Weight

Dimensional drawings

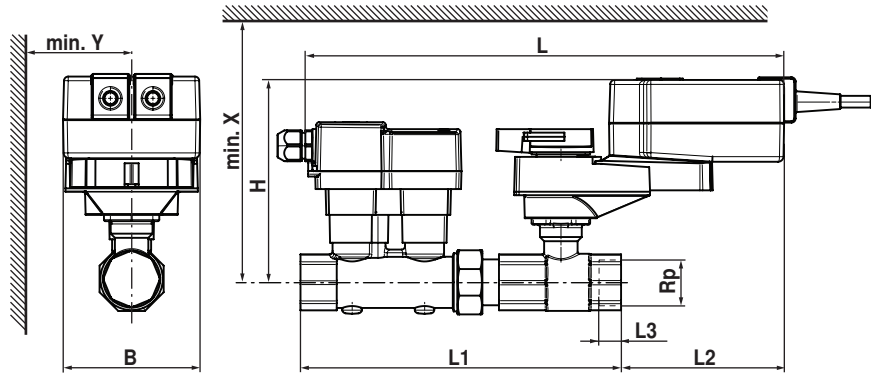

Type	DN []	Rp ["]	L [mm]	L1 [mm]	L2 [mm]	L3 [mm]	B [mm]	H [mm]	X [mm]	Y [mm]	Weight
EP015R+KMP	15	1/2	331	192	128	13	98	143	195	77	1.5 kg
EP020R+KMP	20	3/4	348	211	123	14	98	145	195	77	1.8 kg
EP025R+KMP	25	1	344	230	116	16	98	145	197	77	2.0 kg
EP032R+KMP	32	1 1/4	359	255	110	19	98	150	201	77	2.8 kg
EP040R+KMP	40	1 1/2	361	267	105	19	98	150	211	77	3.3 kg
EP050R+KMP	50	2	381	288	100	22	98	156	212	77	4.4 kg

Further documentation

- Overview MP Cooperation Partners
- Tool connections
- Introduction to MP-Bus Technology
- General notes for project planning