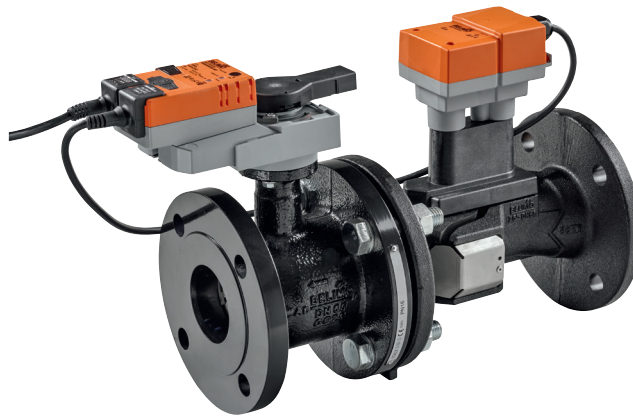

Characterised control valve with sensor-operated flow control with fail-safe, 2-way, Flange, PN 25 (EPIV)

- Nominal voltage AC/DC 24 V
- Control modulating, communicative
- For closed cold and warm water systems
- For modulating control of air-handling and heating systems on the water side
- Communication via Belimo MP-Bus or conventional control
- Conversion of active sensor signals and switching contacts

Type overview

Type	DN []	DN ["]	V'nom [l/s]	V'nom [l/min]	kvs theor. [m³/h]	PN []	n(gl) []
EP065F+KMP	65	2 1/2	8	480	50	25	3.2
EP080F+KMP	80	3	11	660	75	25	3.2
EP100F+KMP	100	4	20	1200	127	25	3.2
EP125F+KMP	125	5	31	1860	195	25	3.2
EP150F+KMP	150	6	45	2700	254	25	3.2

kvs theory: Theoretical kvs value for pressure drop calculation

Technical data

Electrical data	Nominal voltage	AC/DC 24 V
	Nominal voltage frequency	50/60 Hz
	Nominal voltage range	AC 19.2...28.8 V / DC 21.6...28.8 V
	Power consumption in operation	10 W (DN 65...80) 13 W (DN 100...150)
	Power consumption in rest position	5 W (DN 65...80) 7 W (DN 100...150)
	Power consumption for wire sizing	20 VA (DN 65...80) 24 VA (DN 100...150)
	Connection supply / control	Cable 1 m, 4 x 0.75 mm²
	Parallel operation	Yes (note the performance data)
Functional data	Torque motor	20 Nm (DN 65...80) 40 Nm (DN 100...150)
	Communicative control	MP-Bus
	Operating range Y	2...10 V
	Input Impedance	100 kΩ
	Operating range Y variable	Start point 0.5...24 V End point 8.5...32 V
	Options positioning signal	Modulating (DC 0...32 V)
	Position feedback U	2...10 V
	Position feedback U note	Max. 1 mA
	Position feedback U variable	Start point 0.5...8 V End point 2...10 V
	Sound power level Motor	45 dB(A)
	Adjustable flow rate V'max	30...100% of Vnom
	Control accuracy	±6% (of 25...100% Vnom) @ 20°C / Glycol 0% vol.
	Control accuracy note	±10% (of 25...100% V'nom)
	Fluid	Cold and warm water, water with glycol up to max. 50% vol.
	Fluid temperature	-10...120°C
	Permissible operating pressure ps	1600 kPa
	Close-off pressure Δps	690 kPa
Differential pressure Δpmax	340 kPa	
Flow characteristic	equal percentage (VDI/VDE 2178), optimised in the opening range (switchable to linear)	
Leakage rate	air-bubble tight, leakage rate A (EN 12266-1)	
Pipe connectors	Flange PN 16 according to EN 1092-2	

Technical data

Functional data	Installation position	upright to horizontal (in relation to the stem)
	Servicing	maintenance-free
	Manual override	with push-button, can be locked
Flow measurement	Measuring principle	Ultrasonic volumetric flow measurement
	Measuring accuracy flow	$\pm 2\%$ (of 25...100% V _{nom}) @ 20 °C / Glycol 0% vol.
	Measuring accuracy flow note	$\pm 6\%$ (of 25...100% V _{nom})
	Min. flow measurement	1% of V _{nom}
Safety	Protection class IEC/EN	III Safety Extra-Low Voltage (SELV)
	Degree of protection IEC/EN	IP54
	EMC	CE according to 2014/30/EU
	Mode of operation	Type 1
	Rated impulse voltage supply / control	0.8 kV
	Control pollution degree	3
	Ambient temperature	-30...50 °C
	Storage temperature	-20...80 °C
	Ambient humidity	Max. 95% r.H., non-condensing
Materials	Flow measuring pipe	EN-GJL-250 (GG 25), with protective paint
	Closing element	stainless steel AISI 316
	Stem seal	EPDM
	Ball seat	PTFE, O-ring Viton

Safety notes



- This device has been designed for use in stationary heating, ventilation and air-conditioning systems and must not be used outside the specified field of application, especially in aircraft or in any other airborne means of transport.
- Outdoor application: only possible in case that no (sea) water, snow, ice, insolation or aggressive gases interfere directly with the actuator and that is ensured that the ambient conditions remain at any time within the thresholds according to the data sheet.
- Only authorised specialists may carry out installation. All applicable legal or institutional installation regulations must be complied during installation.
- The device contains electrical and electronic components and must not be disposed of as household refuse. All locally valid regulations and requirements must be observed.

Product features

Mode of operation The final controlling device is comprised of three components: characterised control valve (CCV), measuring pipe with volumetric flow sensor and the actuator itself. The adjusted maximum flow (V_{max}) is assigned to the maximum positioning signal (typically 10 V / 100%). The final controlling device can be controlled communicative or analogue. The fluid is detected by the sensor in the measuring pipe and is applied as the flow value. The measured value is balanced with the setpoint. The actuator corrects the deviation by changing the valve position. The angle of rotation α varies according to the differential pressure through the final controlling element (see volumetric flow curves).

Flow characteristic

Flow rate curves

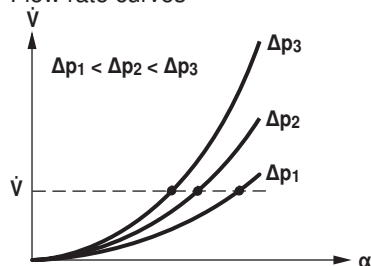

Product features**Transmission behaviour HE**

Heat exchanger transmission behaviour

Depending on the construction, temperature spread, fluid characteristics and hydraulic circuit, the power Q is not proportional to the water volumetric flow \dot{V} (Curve 1). With the classical type of temperature control, an attempt is made to maintain the control signal Y proportional to the power Q (Curve 2). This is achieved by means of an equal-percentage valve characteristic curve (Curve 3).

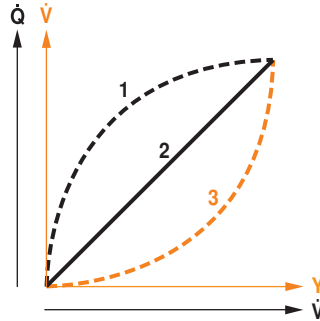

Product features

Control characteristics

The fluid velocity is measured in the measuring component (sensor electronics) and converted to a flow rate signal.
 The positioning signal Y corresponds to the power Q via the exchanger, the volumetric flow is regulated in the EPIV. The control signal Y is converted into an equal-percentage characteristic curve and provided with the \dot{V}_{max} value as the new reference variable w . The momentary control deviation forms the positioning signal Y_1 for the actuator.
 The specially configured control parameters in connection with the precise flow rate sensor ensure a stable quality of control. They are however not suitable for rapid control processes, i.e. for domestic water control.
 U_5 displays the measured volumetric flow as voltage (factory setting). As an alternative, U_5 can be used for displaying the valve opening angle. It is always in reference to the respective \dot{V}_{nom} , i.e. if \dot{V}_{max} is e.g. 50% of \dot{V}_{nom} , then $Y = 10\text{ V}$, $U_5 = 5\text{ V}$.

1. Standard equal percentage $\dot{V}_{max} = \dot{V}_{nom} / 2$ effect $\dot{V}_{max} < \dot{V}_{nom}$

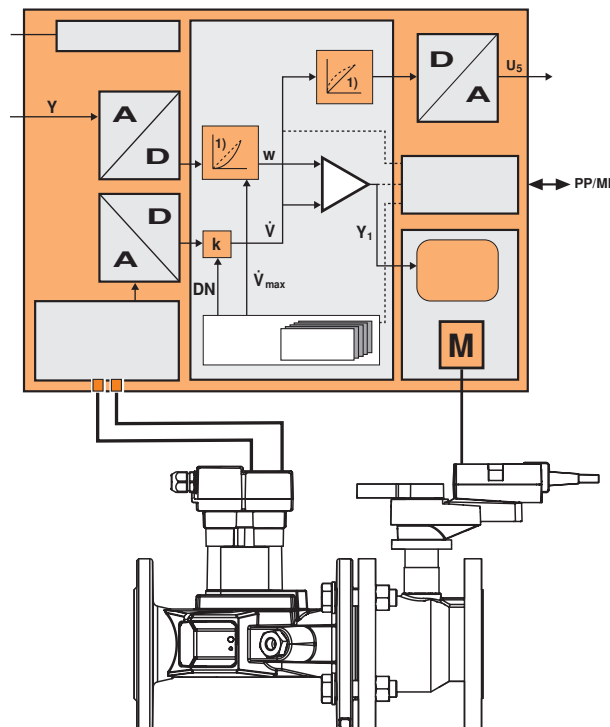
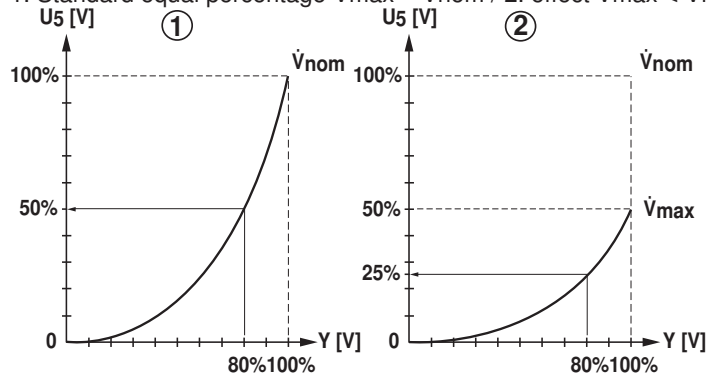

Product features

Definition Flow control
 V'_{nom} is the maximum possible flow.

V'_{max} is the maximum flow rate which has been set with the greatest positioning signal. V'_{max} can be set between 30% and 100% of V'_{nom} .

V'_{min} 0% (non-variable).

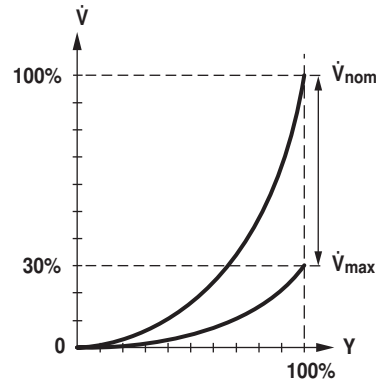

Creep flow suppression Given the very low flow speed in the opening point, this can no longer be measured by the sensor within the required tolerance. This range is overridden electronically.

Opening valve

The valve remains closed until the volumetric flow required by the positioning signal Y corresponds to 1% of V'_{nom} . The control along the valve characteristic curve is active after this value has been exceeded.

Closing valve

The control along the valve characteristic curve is active up to the required flow rate of 1% of V'_{nom} . Once the level falls below this value, the flow rate is maintained at 1% of V'_{nom} . If the level falls below the flow rate of 0.5% of V'_{nom} required by the reference variable Y , then the valve will close.

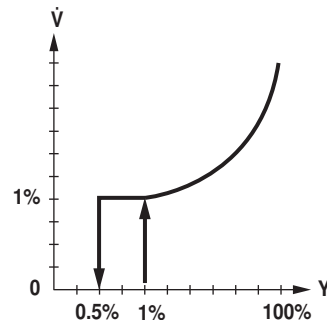

Converter for sensors Connection option for a sensor (active sensor or switching contact). The MP actuator serves as an analogue/digital converter for the transmission of the sensor signal via MP-Bus to the higher level system.

Parametrisable actuators The factory settings cover the most common applications. Single parameters can be modified with the Belimo Service Tools MFT-P or ZTH EU.

Positioning signal inversion This can be inverted in cases of control with an analogue positioning signal. The inversion causes the reversal of the standard behaviour, i.e. at a positioning signal of 0%, regulation is to V'_{max} , and the valve is closed at a positioning signal of 100%.

Hydraulic balancing With the Belimo tools, the maximum flow rate (equivalent to 100% requirement) can be adjusted on-site, simply and reliably, in a few steps. If the device is integrated in the management system, then the balancing can be handled directly by the management system.

Manual override Manual override with push-button possible (the gear is disengaged for as long as the button is pressed or remains locked).

High functional reliability The actuator is overload protected, requires no limit switches and automatically stops when the end stop is reached.

Accessories

	Description	Type
Gateways	Gateway MP zu BACnet MS/TP	UK24BAC
	Gateway MP to Modbus RTU	UK24MOD
	Gateway MP to LonWorks	UK24LON
	Gateway MP to KNX	UK24EIB
Electrical accessories	Description	Type
	Stem heating flange F05 DN25...100 (30 W)	ZR24-F05
	Connection cable 5 m, A: RJ11 6/4 ZTH EU, B: 6-pin service socket for Belimo device	ZK1-GEN
	Connection cable 5 m, A: RJ11 6/4 ZTH EU, B: free wire end for connection to MP/PP terminal	ZK2-GEN
	Connecting board MP-Bus for wiring boxes EXT-WR-FP...MP MP-Bus power supply for MP actuators	ZFP2-MP ZN230-24MP
Service Tools	Description	Type
	Service Tool, Setting tool with ZIP-USB function	ZTH EU
	Belimo PC-Tool, Software for adjustments and diagnostics	MFT-P
	Adapter for Service-Tool ZTH	MFT-C
	Level converter USB/MP	ZIP-USB-MP

Electrical installation

Notes

- Connection via safety isolating transformer.
- Parallel connection of other actuators possible. Observe the performance data.

Wiring diagrams

AC/DC 24 V, modulating

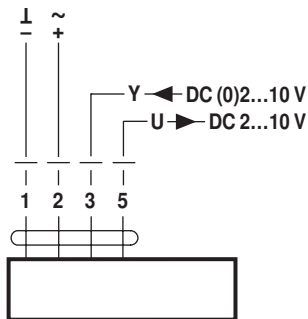

Cable colours:
 1 = black
 2 = red
 3 = white
 5 = orange

Operation on the MP-Bus

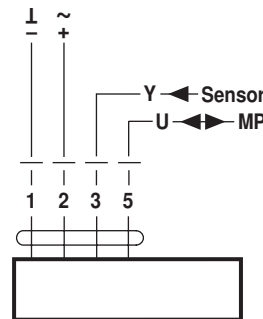

Cable colours:
 1 = black
 2 = red
 3 = white
 5 = orange

Functions

Functions when operated on MP-Bus

Connection on the MP-Bus

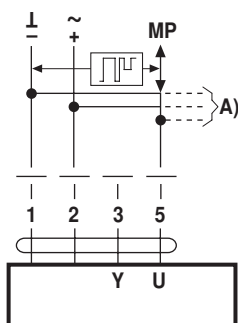

A) more actuators and sensors (max.8)

MP-Bus Network topology

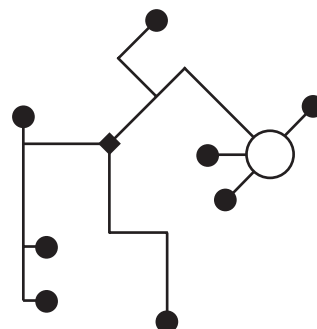

There are no restrictions for the network topology (star, ring, tree or mixed forms are permitted). Supply and communication in one and the same 3-wire cable

- no shielding or twisting necessary
- no terminating resistors required

Functions

Connection of active sensors

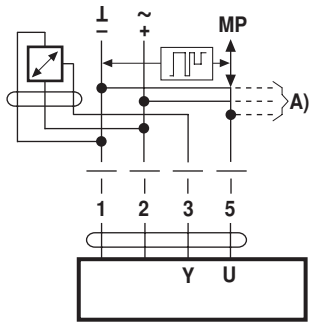

A) more actuators and sensors (max.8)
 • Supply AC/DC 24 V
 • Output signal DC 0...10 V (max. DC 0...32 V)
 • Resolution 30 mV

Connection of external switching contact

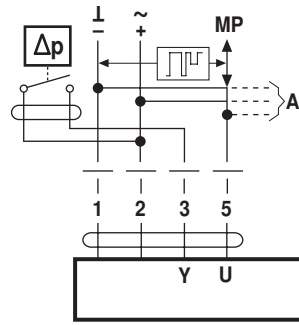

A) more actuators and sensors (max.8)
 • Switching current 16 mA @ 24 V
 • Start point of the operating range must be parameterised on the MP actuator as ≥ 0.5 V

Functions for devices with specific parameters (Parametrisation necessary)

Override control and limiting with AC 24 V with relay contacts

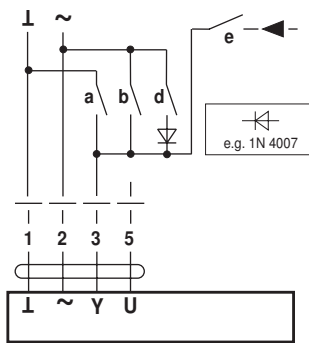

	a	b	d	e
Close				
\dot{V}_{max}				
Open				
Y				

Override control and limiting with DC 24 V with relay contacts

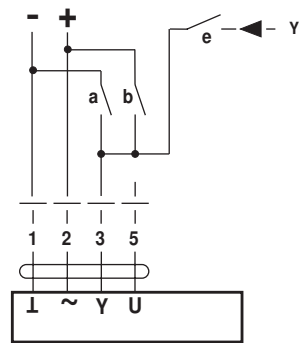

	a	b	d	e
Close				
\dot{V}_{max}				
Y				

Control 3-point

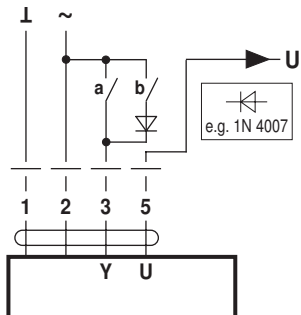

Position control: $90^\circ = 100s$
 Flow control: $V_{max} = 100s$

Installation notes

Recommended installation positions

The ball valve can be installed upright to horizontal. The ball valve may not be installed in a hanging position, i.e. with the stem pointing downwards.

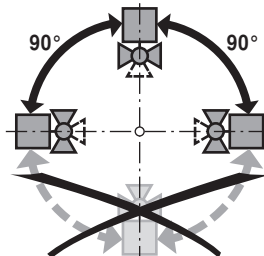

Mounting position in the return

Installation in the return is recommended.

Installation notes

- Water quality requirements** The water quality requirements specified in VDI 2035 must be adhered to. Belimo valves are regulating devices. For the valves to function correctly in the long term, they must be kept free from particle debris (e.g. welding beads during installation work). The installation of a suitable strainer is recommended. The water must exhibit a conductivity $\geq 20 \mu\text{S}/\text{cm}$ during operation for correct functioning. It should be noted that, under normal circumstances, even filling water with a lower conductivity will experience an elevation of its conductivity to above the minimum required value during filling and that the system can thus be put into operation. Elevation of conductivity during filling caused by:
- untreated residual water from pressure test or pre-rinsing
 - metal salts (e.g. surface rust) dissolved out of the raw material
- Stem heating** In cold water applications and warm humid ambient air can cause condensation in the actuators. This can lead to corrosion in the gear box of the actuator and causes a breakdown of it. In such applications, the use of a stem heating is provided. The stem heating must be enabled only when the system is in operation, because it does not have temperature control.
- Servicing** Ball valves, rotary actuators and sensors are maintenance-free. Before any service work on the final controlling device is carried out, it is essential to isolate the rotary actuator from the power supply (by unplugging the electrical cable if necessary). Any pumps in the part of the piping system concerned must also be switched off and the appropriate slide valves closed (allow all components to cool down first if necessary and always reduce the system pressure to ambient pressure level). The system must not be returned to service until the ball valve and the rotary actuator have been correctly reassembled in accordance with the instructions and the pipeline has been refilled by professionally trained personnel.
- Flow direction** The direction of flow, specified by an arrow on the housing, is to be complied with, since otherwise the flow rate will be measured incorrectly.
- Inlet section** In order to achieve the specified measuring accuracy, a flow-calming section or inflow section in the direction of the flow is to be provided upstream from the flow sensor. Its dimensions should be at least $5 \times \text{DN}$.

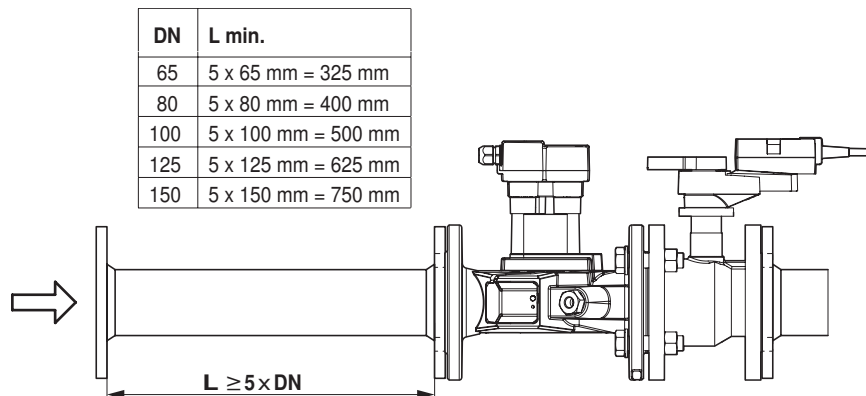

General notes

- Valve selection** The valve is determined using the maximum required flow rate V'_{max} . A calculation of the kvs value is not required.
 $V'_{\text{max}} = 30 \dots 100\%$ of V'_{nom}
 If no hydraulic data are available, then the same valve DN can be selected as the heat exchanger nominal diameter.

General notes

Minimum differential pressure (pressure drop)

The minimum required differential pressure (pressure drop through the valve) for achieving the desired volumetric flow \dot{V}_{max} can be calculated with the aid of the theoretical kvs value (see type overview) and the below-mentioned formula. The calculated value is dependent on the required maximum volumetric flow \dot{V}_{max} . Higher differential pressures are compensated for automatically by the valve.

Formula

$$\Delta p_{min} = 100 \times \left(\frac{\dot{V}_{max}}{k_{vs \text{ theor.}}} \right)^2$$

$\Delta p_{min}: \text{kPa}$
 $\dot{V}_{max}: \text{m}^3/\text{h}$
 $k_{vs \text{ theor.}}: \text{m}^3/\text{h}$

Example (DN100 with the desired maximum flow rate = 50% \dot{V}_{nom})
 EP100F+KMP

kvs theor. = 127 m³/h
 \dot{V}_{nom} = 1200 l/min
 50% * 1200 l/min = 600 l/min = 36 m³/h

$$\Delta p_{min} = 100 \times \left(\frac{\dot{V}_{max}}{k_{vs \text{ theor.}}} \right)^2 = 100 \times \left(\frac{36 \text{ m}^3/\text{h}}{127 \text{ m}^3/\text{h}} \right)^2 = 8 \text{ kPa}$$

Valve selection

In case of a flow sensor error, the EPIV will switch from flow control to position control. Once the error disappears, the EPIV will switch back to the normal control setting.

Service

Service Tools connection

The actuator can be parametrised by ZTH EU via the service socket. For an extended parametrisation the PC tool can be connected.

Connection ZTH EU / PC-Tool

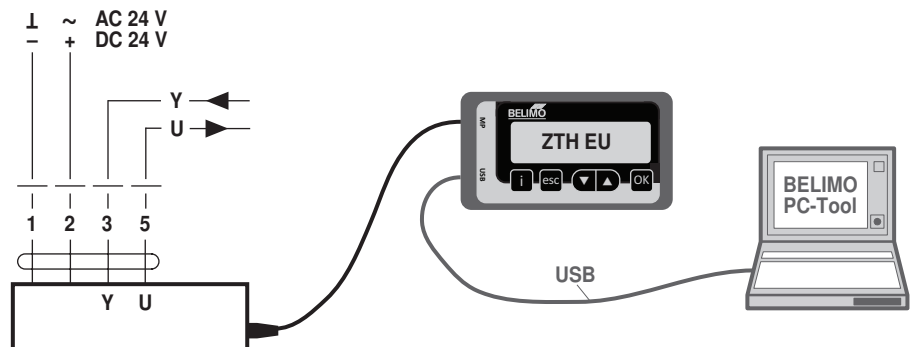

Dimensions / Weight

Dimensional drawings

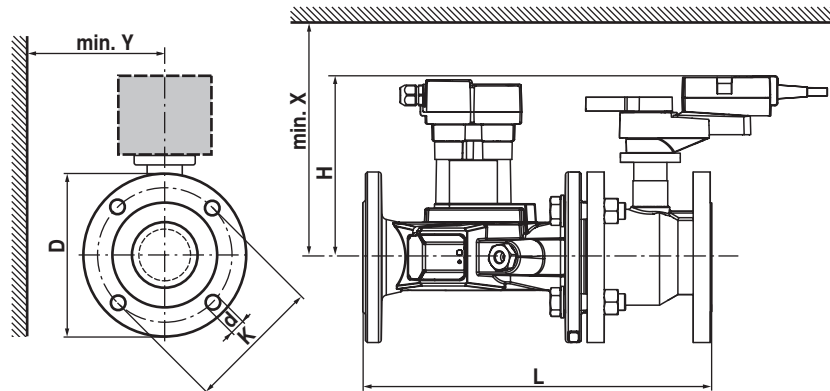

If Y < 180 mm, the extension of the hand crank must be demounted as necessary.

Type	DN []	L [mm]	H [mm]	D [mm]	d [mm]	K [mm]	X [mm]	Y [mm]	Weight
EP065F+KMP	65	379	214	185	4 x 19	145	220	150	26 kg
EP080F+KMP	80	430	214	200	8 x 19	160	220	160	35 kg
EP100F+KMP	100	474	239	229	8 x 19	180	240	175	52 kg
EP125F+KMP	125	579	258	252	8 x 19	210	260	190	70 kg
EP150F+KMP	150	651	258	282	8 x 23	240	260	200	90 kg

Further documentation

- Overview MP Cooperation Partners
- Tool connections
- Introduction to MP-Bus Technology
- General notes for project planning