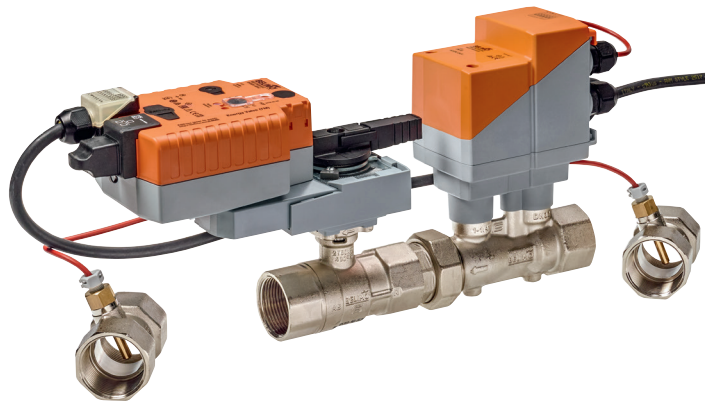

Characterised control valve with sensor-operated flow rate or power control with fail-safe, power and energy-monitoring function, 2-way, internal thread, PN 16 (Energy Valve)

- Nominal voltage AC/DC 24 V
- Control modulating, communicative, hybrid
- For closed cold and warm water systems
- For modulating control of air-handling and heating systems on the water side
- Ethernet 10/100 Mbit/s, TCP/IP, integrated web server
- Communication via BACnet, Modbus, Belimo MP-Bus or conventional control
- optional Belimo Cloud connection
- Design life SuperCaps: 15 years

Type overview

Type	DN []	Rp ["]	V'nom [l/s]	V'nom [l/min]	kvs theor. [m³/h]	PN []	n(gl) []
EV015R+KBAC	15	1/2	0.35	21	2.9	16	3.2
EV020R+KBAC	20	3/4	0.65	39	4.9	16	3.2
EV025R+KBAC	25	1	1.15	69	8.6	16	3.2
EV032R+KBAC	32	1 1/4	1.8	108	14.2	16	3.2
EV040R+KBAC	40	1 1/2	2.5	150	21.3	16	3.2
EV050R+KBAC	50	2	4.8	288	32.0	16	3.2

kvs theory: Theoretical kvs value for pressure drop calculation

Technical data

Electrical data	Nominal voltage	AC/DC 24 V
	Nominal voltage frequency	50/60 Hz
	Nominal voltage range	AC 19.2...28.8 V / DC 21.6...28.8 V
	Power consumption in operation	15 W
	Power consumption in rest position	6.5 W
	Power consumption for wire sizing	26 VA
	Connection supply / control	Cable 1 m, 6 x 0.75 mm ²
	Connection control Ethernet	RJ45 socket
Parallel operation	Yes (note the performance data)	
Functional data	Torque Motor	20 Nm
	Communicative control	BACnet IP, BACnet MS/TP Modbus TCP, Modbus RTU MP-Bus
	Operating range Y	DC 2...10 V
	Input Impedance	100 kΩ
	Operating range Y variable	DC 0.5...10 V
	Position feedback U	DC 2...10 V
	Position feedback U note	Max. 1 mA
	Position feedback U variable	DC 0...10 V DC 0.5...10 V
	Setting fail-safe position	NC/NO or adjustable 0...100% (POP rotary knob)
	Running time fail-safe	35 s / 90°
	Sound power level Motor	45 dB(A)
	Sound power level, fail-safe	61 dB(A)
	Adjustable flow rate V'max	30...100% of Vnom
	Control accuracy	±10% (of 25...100% V'nom)
	Control accuracy note	±6% (of 25...100% Vnom) @ 20° C / Glycol 0% vol.
Configuration	via integrated web server / ZTH EU	

Technical data

Functional data	Media	Cold and warm water, water with glycol up to max. 50% vol.	
	Medium temperature	-10...120°C	
	Permissible pressure ps	1600 kPa	
	Close-off pressure Δp_s	1400 kPa	
	Differential pressure Δp_{max}	350 kPa	
	Differential pressure note	200 kPa for low-noise operation	
	Flow characteristic	equal percentage (VDI/VDE 2178), optimised in the opening range (switchable to linear)	
	Leakage rate	air-bubble tight, leakage rate A (EN 12266-1)	
	Pipe connectors	Internal thread according to ISO 7-1	
	Installation position	upright to horizontal (in relation to the stem)	
	Servicing	maintenance-free	
	Manual override	with push-button	
	Flow measurement	Measuring principle	Ultrasonic volumetric flow measurement
		Measuring accuracy flow	$\pm 6\%$ (of 25...100% V'nom)
Measuring accuracy flow note		$\pm 2\%$ (of 25...100% Vnom) @ 20°C / Glycol 0% vol.	
Min. flow measurement		1% of V'nom	
Temperature measurement	Measuring accuracy absolute temperature	$\pm 0.6^\circ\text{C}$ @ 60°C (Pt1000 EN60751 Class B)	
	Measuring accuracy temperature difference	$\pm 0.23\text{ K}$ @ $\Delta T = 20\text{ K}$	
	Resolution	0.05°C	
Safety	Protection class IEC/EN	III Protective extra-low voltage (PELV)	
	Degree of protection IEC/EN	IP54	
	Degree of protection note	IP protection when using protective cap or protective grommet for RJ45 socket	
	EMC	CE according to 2014/30/EU	
	Mode of operation	Type 1.AA	
	Rated impulse voltage supply / control	0.8 kV	
	Control pollution degree	3	
	Ambient temperature	-30...50°C	
	Storage temperature	-40...80°C	
	Ambient humidity	Max. 95% r.H., non-condensing	
Materials	Flow measuring pipe	Brass body nickel-plated	
	Closing element	Stainless steel	
	Stem seal	EPDM O-ring	
	Immersion sleeve	Brass	
	T-Piece	Brass body nickel-plated	
Terms	Abbreviations	POP = Power off position / fail-safe position	

Safety notes



- This device has been designed for use in stationary heating, ventilation and air-conditioning systems and must not be used outside the specified field of application, especially in aircraft or in any other airborne means of transport.
- Outdoor application: only possible in case that no (sea) water, snow, ice, insolation or aggressive gases interfere directly with the actuator and that is ensured that the ambient conditions remain at any time within the thresholds according to the data sheet.
- Only authorised specialists may carry out installation. All applicable legal or institutional installation regulations must be complied during installation.
- The device contains electrical and electronic components and must not be disposed of as household refuse. All locally valid regulations and requirements must be observed.

Product features

Mode of operation The HVAC performance device is comprised of four components: characterised control valve (CCV), measuring pipe with volumetric flow sensor, temperature sensors and the actuator itself. The adjusted maximum flow (V'_{max}) is assigned to the maximum positioning signal (typically 10 V / 100%). Alternatively, the positioning signal can be assigned to the valve opening angle or to the power required on the heat exchanger (see power control). The HVAC performance device can be controlled communicative or analogue. The medium is detected by the sensor in the measuring pipe and is applied as the flow value. The measured value is balanced with the setpoint. The actuator corrects the deviation by changing the valve position. The angle of rotation α varies according to the differential pressure through the final controlling element (see flow rate curves).
 With the supply voltage the integrated condensers will be charged. Interrupting the supply voltage causes the valve to be moved to the selected fail-safe position by means of stored electrical energy.

Flow characteristic

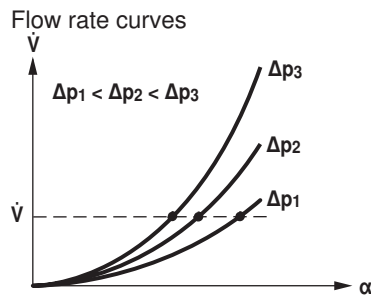

Pre-charging time (start up) The capacitor actuators require a pre-charging time. This time is used for charging the capacitors up to a usable voltage level. This ensures that, in the event of a power failure, the actuator can move at any time from its current position into the preset fail-safe position. The duration of the pre-charging time depends mainly on how long the power was interrupted.

Typical pre-charging time

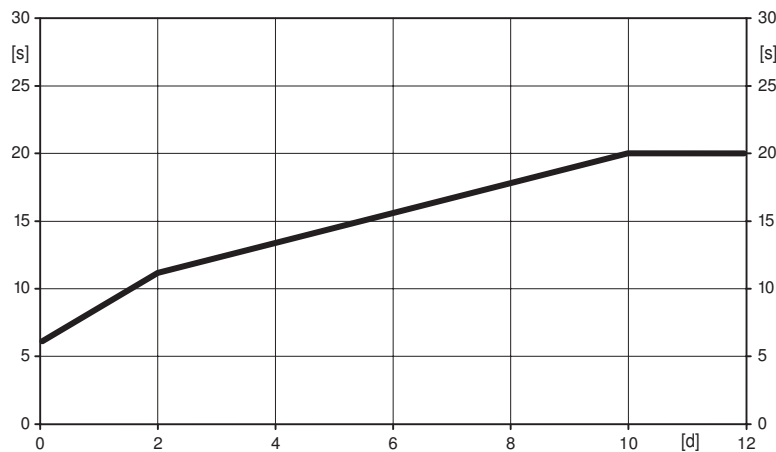

	[d]				
	0	1	2	7	≥10
[s]	6	9	11	16	20

[d] = Electricity interruption in days
 [s] = Pre-charging time in seconds

Delivery condition (capacitors) The actuator is completely discharged after delivery from the factory, which is why the actuator requires approximately 20 s pre-charging time before initial commissioning in order to bring the capacitors up to the required voltage level.

Setting fail-safe position (POP) The «fail-safe position» rotary knob can be used to adjust the desired fail-safe position 0...100% in 10% increments. The rotary knob always refers to the adapted angle of rotation range. In the event of a power failure, the actuator will move into the selected fail-safe position.

Product features

Transmission behaviour HE

Heat exchanger transmission behaviour
 Depending on the construction, temperature spread, medium and hydraulic circuit, the power Q is not proportional to the water volumetric flow \dot{V} (Curve 1). With the classical type of temperature control, an attempt is made to maintain the control signal Y proportional to the power Q (Curve 2). This is achieved by means of an equal-percentage valve characteristic curve (Curve 3).

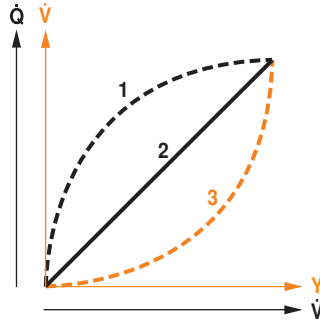

Power control

Alternatively, the positioning signal Y can be assigned to the output power required on the heat exchanger.
 Depending on the water temperature and air conditions, the Energy Valve ensures the amount of water required to achieve the desired power.

Maximum controllable power on heat exchanger in power control mode:

DN 15	80 kW
DN 20	140 kW
DN 25	250 kW
DN 32	380 kW
DN 40	530 kW
DN 50	1010 kW

Control characteristics

The specially configured control parameters in connection with the precise velocity sensor ensure a stable quality of control. They are, however, not suitable for rapid control processes, i.e. for domestic water control.

Definition

Flow control

\dot{V}'_{nom} is the maximum possible flow.

\dot{V}'_{max} is the maximum flow rate which has been set with the greatest positioning signal. \dot{V}'_{max} can be set between 30% and 100% of \dot{V}'_{nom} .

\dot{V}'_{min} 0% (non-variable).

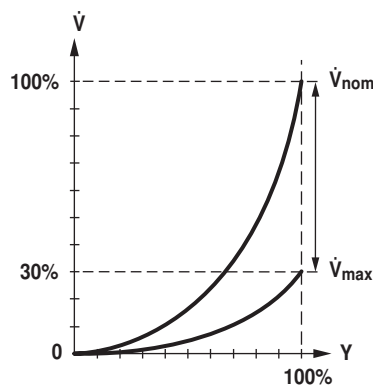

Product features

Definition Power control
 Q'_{nom} is the maximum possible power output on the heat exchanger.

Q'_{max} is the maximum power output on the heat exchanger which has been set with the greatest positioning signal. Q'_{max} can be set between 1% and 100% of Q'_{nom} .

Q'_{min} 0% (non-variable).

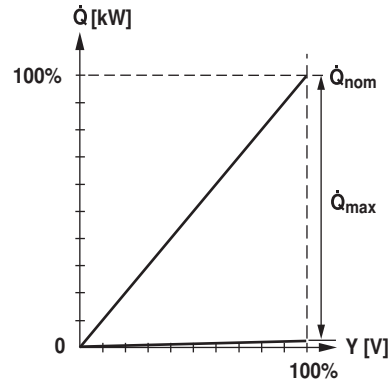

Creep flow suppression Given the very low flow speed in the opening point, this can no longer be measured by the sensor within the required tolerance. This range is overridden electronically.

Opening valve

The valve remains closed until the volumetric flow required by the positioning signal Y corresponds to 1% of V'_{nom} . The control along the valve characteristic curve is active after this value has been exceeded.

Closing valve

The control along the valve characteristic curve is active up to the required flow rate of 1% of V'_{nom} . Once the level falls below this value, the flow rate is maintained at 1% of V'_{nom} . If the level falls below the flow rate of 0.5% of V'_{nom} required by the reference variable Y , then the valve will close.

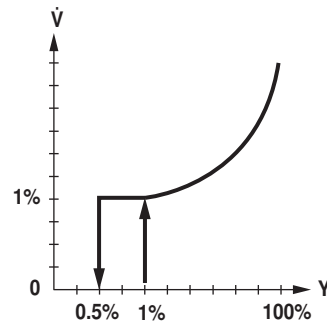

Product features

Communication The configuration can be carried out through the integrated web server (RJ45 connection to the web browser) or by communicative means. Additional information regarding the integrated web server can be found in the separate documentation.

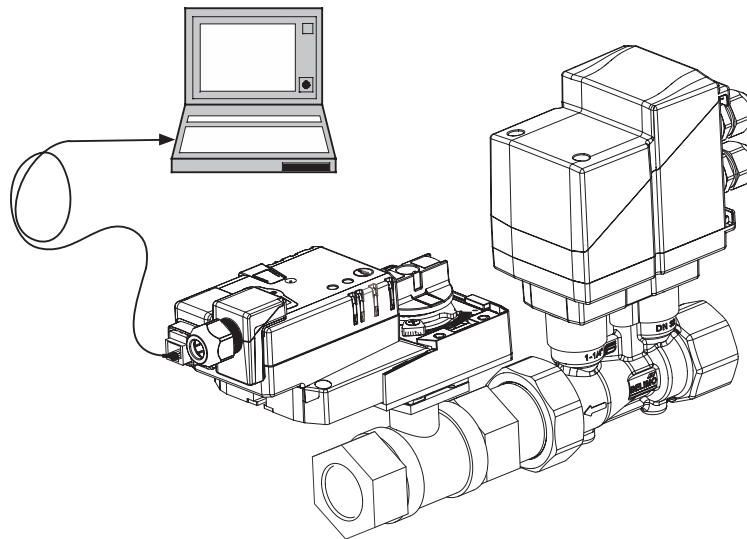

“Peer to Peer” connection

<http://belimo.local:8080>

The Notebook must be set to “DHCP”.
Make sure that only one network connection is active.

Standard IP address:

<http://192.168.0.10:8080>
Static IP address

Password (read-only):

User name: «guest»
Password: «guest»

Positioning signal inversion

This can be inverted in cases of control with an analogue positioning signal. The inversion causes the reversal of the standard behaviour, i.e. at a positioning signal of 0%, regulation is to $V'max$ or $Q'max$, and the valve is closed at a positioning signal of 100%.

Hydraulic balancing

Via the integrated web server, the maximum flow rate (equivalent to 100% requirement) can be adjusted on the device itself, simply and reliably, in a few steps. If the device is integrated in the management system, then the balancing can be handled directly by the management system.

Delta-T manager

If a heating or cooling register is operated with a differential temperature that is too low and thus with a flow rate that is too high, this will not result in an increased power output.

Nevertheless, heating or cooling machines must provide the energy at a lower degree of efficiency. This means, that pumps circulate too much water and increase energy consumption unnecessarily.

With the aid of the Energy Valve, it is simple to discover that operation is being carried out at a differential temperature that is too low, resulting in the inefficient use of energy. Necessary setting adjustments can now be carried out quickly and easily at any time. The integrated differential temperature limiting offers the user the possibility of defining a low limit value. The Energy Valve limits the flow rate automatically to prevent the level from falling below this value.

The settings of the Delta-T manager can be made either directly on the web server or via the Belimo Cloud a direct analysis of the Delta-T behavior is carried out by Belimo experts.

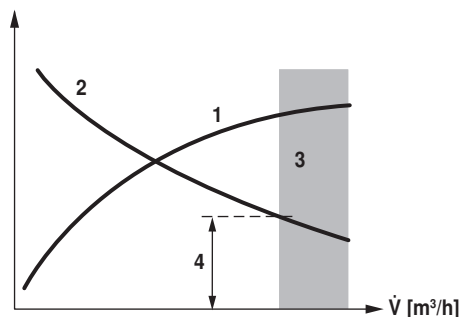

Power output of the heating or cooling registers 1
Diff. temperature between supply and return 2
Loss zone (heating or cooling register saturation) 3
Adjustable minimum differential temperature 4

Combination analogue - communicative (hybrid mode)

With conventional control by means of an analogue positioning signal, the integrated web server, BACnet, Modbus or MP-Bus can be used for the communicative position feedback.

Product features

Power and energy monitoring function	<p>The final controlling device is equipped with two temperature sensors. A sensor (T2) must be installed at the valve and the second sensor (T1) must be installed on-site on the other side of the water circulation. The two sensors are enclosed with the system already wired. The sensors are used to record the medium temperature of the supply and return lines of the consumer (heating/cooling coil). As the water quantity is also known, thanks to the volumetric flow measurement integrated in the system, the power released from the consumer can be calculated. Furthermore, the heating/cooling energy is also determined automatically by means of the evaluation of the power over time.</p> <p>The current data, e.g. temperatures, volumetric flow volumes, exchanger energy consumption etc. can be recorded and accessed at any time by means of web browsers or communication.</p>
Data recording	<p>The recorded data (integrated data recording for 13 months) can be used for the optimisation of the overall system and for the determination of the performance of the consumer.</p> <p>Download csv files through web browser.</p>
Belimo Cloud	<p>Additional Services are available, if the Energy Valve is connected to the Belimo Cloud: for instance, several devices may be managed via Internet. Also Belimo experts may help analyse the delta-T behavior or provide written reports about the Energy Valve performance. Under certain conditions, the product warranty according to the applicable Terms and Conditions of Sale may be prolonged. Further details may be found under [www.belimo.com/ext-warranty]</p>
Manual override	<p>Manual control with push-button possible - temporary. The gear is disengaged and the actuator decoupled for as long as the button is pressed.</p>
High functional reliability	<p>The actuator is overload protected, requires no limit switches and automatically stops when the end stop is reached.</p>

Accessories

	Description	Type
Electrical accessories	Grommet for RJ connection module Multipack 50 pcs.	Z-STRJ.1
	Connection cable 5 m, A: RJ11 6/4, B: 6-pin New Generation for ZTH EU	ZK1-GEN
Mechanical accessories	Description	Type
	Pipe connector for ball valve with internal thread DN 15 Rp 1/2"	ZR2315
	Pipe connector for ball valve with internal thread DN 20 Rp 3/4"	ZR2320
	Pipe connector for ball valve with internal thread DN 25 Rp 1"	ZR2325
	Pipe connector for ball valve with internal thread DN 32 Rp 1 1/4"	ZR2332
	Pipe connector for ball valve with internal thread DN 40 Rp 1 1/2"	ZR2340
	Pipe connector for ball valve with internal thread DN 50 Rp 2"	ZR2350
Service Tools	Description	Type
	Service tool, Setting tool with ZIP-USB function	ZTH EU

Electrical installation



Notes

- Connection via safety isolating transformer.
- Parallel connection of other actuators possible. Observe the performance data.
- The wiring of the line for BACnet MS/TP / Modbus RTU is to be carried out in accordance with applicable RS485 regulations.
- Modbus / BACnet: Supply and communication are not galvanically isolated. Connect earth signal of the devices with one another.

Electrical installation

Wiring diagrams

Conventional operation

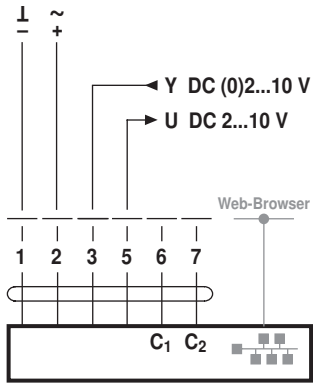

Cable colours:

- 1 = black
- 2 = red
- 3 = white
- 5 = orange
- 6 = pink
- 7 = grey

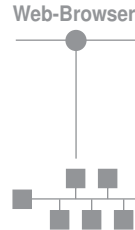

Connection of a notebook for parameterisation and manual control via RJ45.

Optional connection via RJ45 (direct connection Notebook / connection via Intranet or Internet) for access to the integrated web server

MP-Bus, supply via 3-wire connection

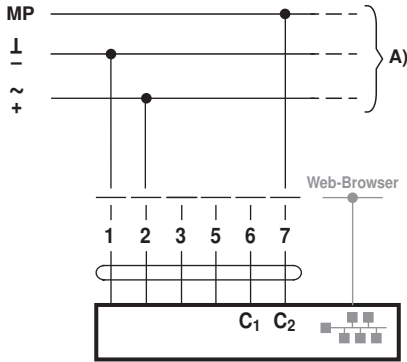

A) Additional actuators and sensors (max. 8)

MP-Bus via 2-wire connection, local power supply

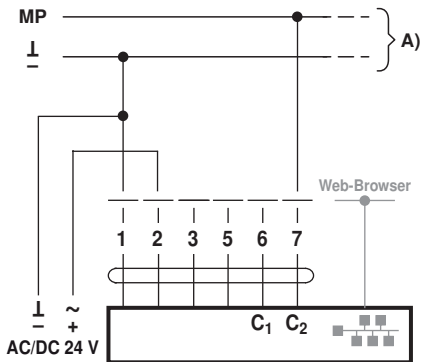

A) Additional actuators and sensors (max. 8)

Network topology

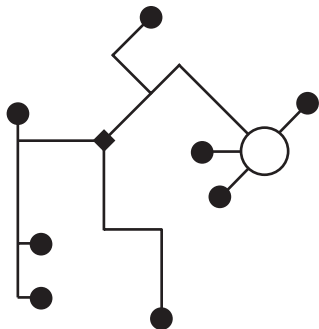

There are no restrictions for the network topology (star, ring, tree or mixed forms are permitted). Supply and communication in one and the same 3-wire cable

- no shielding or twisting necessary
- no terminating resistors required

Functions

Functions for actuators with specific parameters (Configuration with web server)

BACnet MS/TP / Modbus RTU

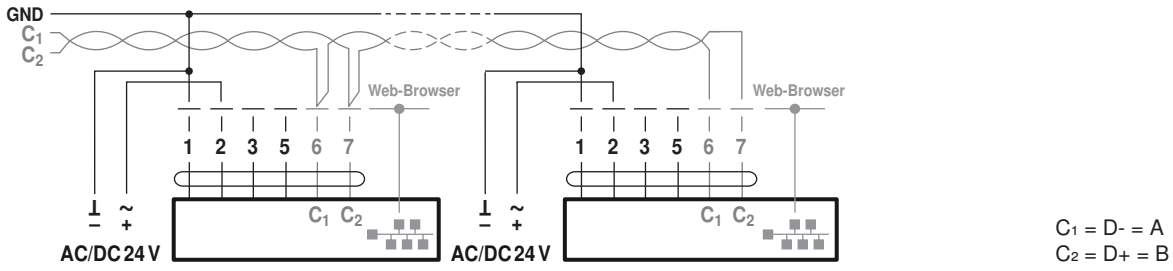

BACnet IP / Modbus TCP

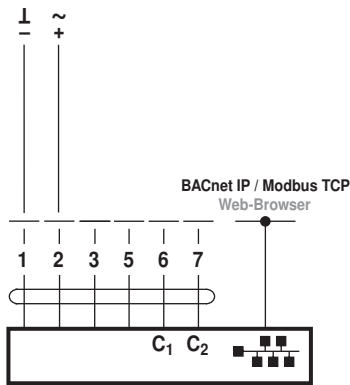

MP-Bus with analog setpoint (hybrid mode)

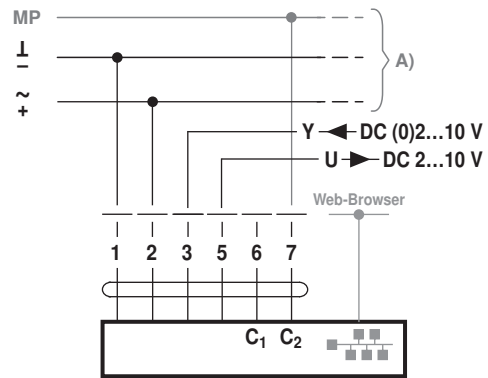

BACnet MS/TP / Modbus RTU with analog setpoint (hybrid mode) BACnet IP / Modbus TCP with analog setpoint (hybrid mode)

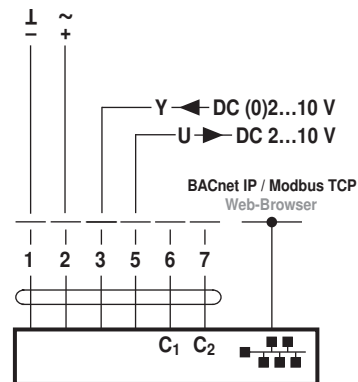
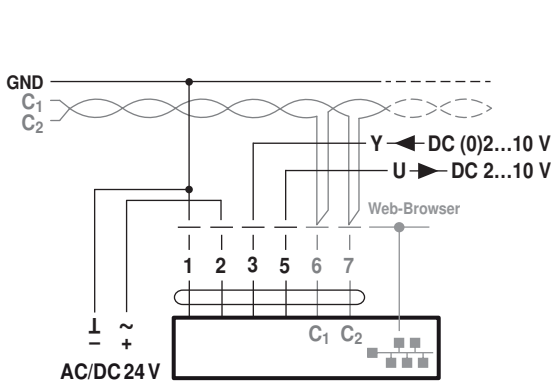

Override control and limiting with DC 24 V with relay contacts (with conventional control or hybrid mode)

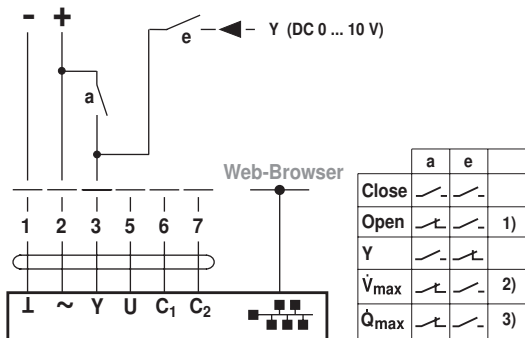

- 1) Position control
- 2) Flow control
- 3) Power control

Operating controls and indicators

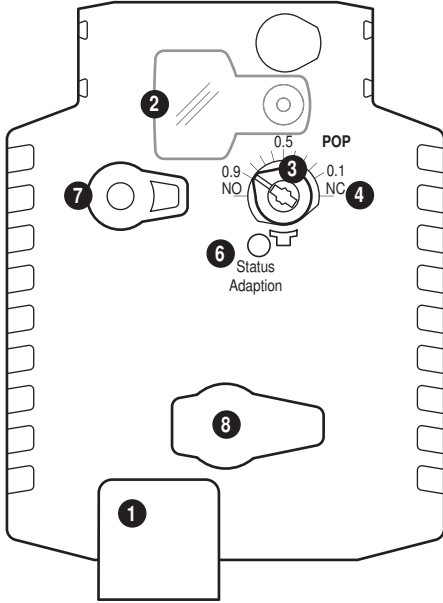

- 1 LED display green**
 Off: No power supply or wiring errors
 On: In operation
 Flickering: Internal communication (Valve/Sensor)
- 2 Cover, POP button**
- 3 POP button**
- 4 Scale for manual adjustment**
- 6 Push-button and LED display yellow**
 On: Adaptation process active
 Flashing: POP function active
 Off: Not in operation, pre-charging time SuperCap, fault SuperCap
 Press button: Triggers angle of rotation adaptation, followed by standard mode
- 7 Gear disengagement button**
 Press button: Gear disengages, motor stops, manual override possible
 Release button: Gear engages, followed by standard mode
- 8 Service plug**
 For connecting the ZTH EU

Setting emergency setting position (POP)

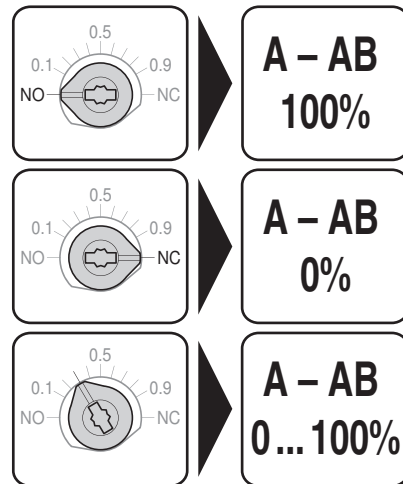
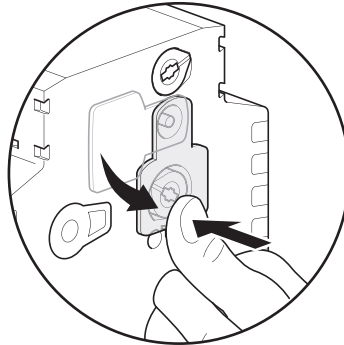
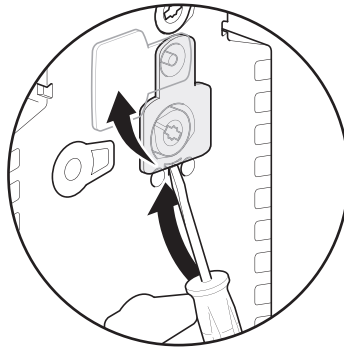

Installation notes

Recommended installation positions The ball valve can be installed upright to horizontal. The ball valve may not be installed in a hanging position, i.e. with the stem pointing downwards.

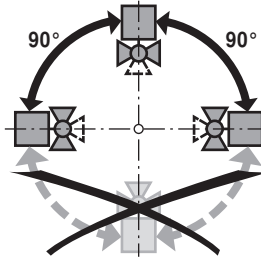

Mounting position in the return Installation in the return is recommended.

Water quality requirements The water quality requirements specified in VDI 2035 must be adhered to. Belimo valves are regulating devices. For the valves to function correctly in the long term, they must be kept free from particle debris (e.g. welding beads during installation work). The installation of a suitable strainer is recommended.

Servicing Ball valves, rotary actuators and sensors are maintenance-free. Before any service work on the final controlling device is carried out, it is essential to isolate the rotary actuator from the power supply (by unplugging the electrical cable if necessary). Any pumps in the part of the piping system concerned must also be switched off and the appropriate slide valves closed (allow all components to cool down first if necessary and always reduce the system pressure to ambient pressure level). The system must not be returned to service until the ball valve and the rotary actuator have been correctly reassembled in accordance with the instructions and the pipeline has been refilled by professionally trained personnel.

Flow direction The direction of flow, specified by an arrow on the housing, is to be complied with, since otherwise the flow rate will be measured incorrectly.

Inlet section In order to achieve the specified measuring accuracy, a flow-calming section or inflow section in the direction of the flow is to be provided upstream from the flow sensor. Its dimensions should be at least 5x DN.

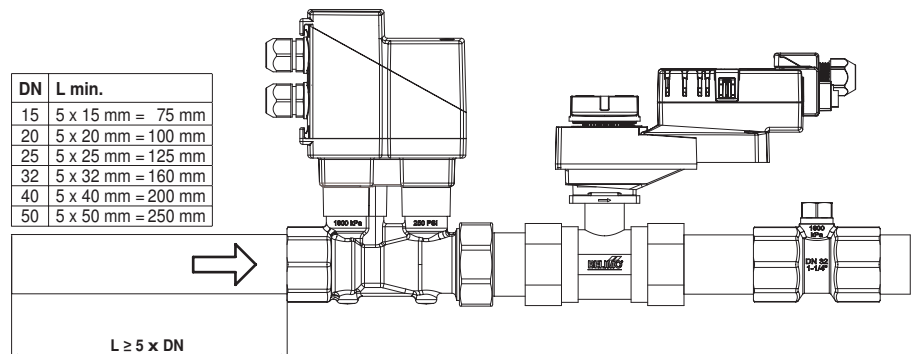

Installation notes

Installation of immersion sleeve and temperature sensor

The valve is equipped with two fully-wired temperature sensors.

- T2: This sensor is installed on site near the valve unit.
- T1: This sensor is installed on site ahead of the consumer (valve in the return line) or after the consumer (valve in the supply line).

Two T-pieces for installation of the temperature sensors in the pipelines are included in the shipment.

Note

The cables between valve unit and temperature sensors may not be either shortened or lengthened.

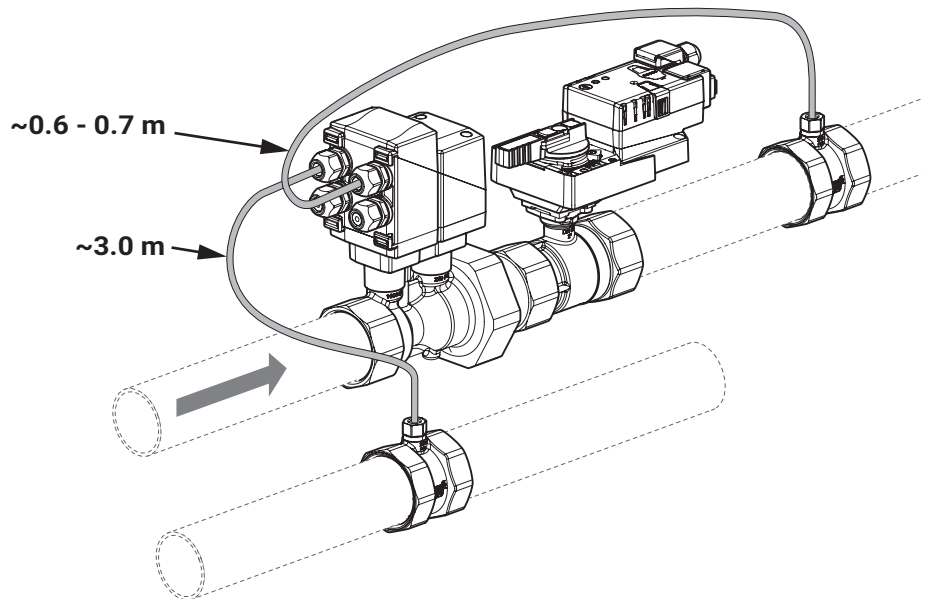

General notes

Valve selection

The valve is determined using the maximum required flow rate \dot{V}'_{max} .

A calculation of the kvs value is not required.

$\dot{V}'_{max} = 30 \dots 100\%$ of \dot{V}'_{nom}

If no hydraulic data are available, then the same valve DN can be selected as the heat exchanger nominal diameter.

Minimum differential pressure (pressure drop)

The minimum required differential pressure (pressure drop through the valve) for achieving the desired volumetric flow \dot{V}'_{max} can be calculated with the aid of the theoretical kvs value (see type overview) and the below-mentioned formula. The calculated value is dependent on the required maximum volumetric flow \dot{V}'_{max} . Higher differential pressures are compensated for automatically by the valve.

Formula

$$\Delta p_{min} = 100 \times \left(\frac{\dot{V}'_{max}}{k_{vs \text{ theor.}}} \right)^2$$

Δp_{min} : kPa
\dot{V}'_{max} : m ³ /h
$k_{vs \text{ theor.}}$: m ³ /h

Example (DN25 with the desired maximum flow rate = 50% \dot{V}'_{nom})

EV025R+KBAC

$k_{vs \text{ theor.}} = 8.6 \text{ m}^3/\text{h}$

$\dot{V}'_{nom} = 69 \text{ l/min}$

$50\% \cdot 69 \text{ l/min} = 34.5 \text{ l/min} = 2.07 \text{ m}^3/\text{h}$

$$\Delta p_{min} = 100 \times \left(\frac{\dot{V}'_{max}}{k_{vs \text{ theor.}}} \right)^2 = 100 \times \left(\frac{2.07 \text{ m}^3/\text{h}}{8.6 \text{ m}^3/\text{h}} \right)^2 = 6 \text{ kPa}$$

Valve selection

In case of a flow sensor error, the Energy Valve will switch from either power or flow control to position control (Delta-T manager will be deactivated).

Once the error disappears, the Energy Valve will switch back to the normal control setting (Delta-T manager activated)

Dimensions / Weight

Dimensional drawings

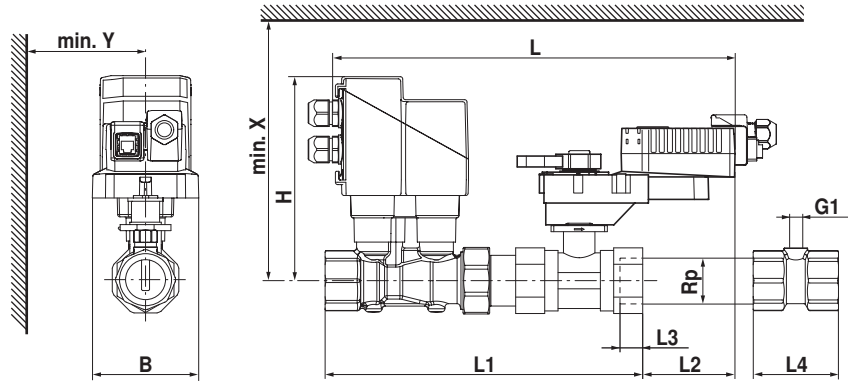

Type	DN []	Rp ["]	L [mm]	L1 [mm]	L2 [mm]	L3 [mm]	B [mm]	H [mm]	G1	L4 [mm]	X [mm]	Y [mm]	Weight
EV015R+KBAC	15	1/2	331	192	128	13	75	160	G1/4"	53	230	77	1.6 kg
EV020R+KBAC	20	3/4	348	211	123	14	75	162	G1/4"	57	232	77	1.9 kg
EV025R+KBAC	25	1	344	230	116	16	75	165	G1/4"	65	235	77	2.1 kg
EV032R+KBAC	32	1 1/4	359	255	110	19	75	168	G1/4"	71	238	77	2.9 kg
EV040R+KBAC	40	1 1/2	361	267	106	19	75	172	G1/4"	71	242	77	3.4 kg
EV050R+KBAC	50	2	381	288	100	22	75	177	G1/4"	80	247	77	5.0 kg

Further documentation

- Overview MP Cooperation Partners
- Tool connections
- General notes for project planning
- Instruction Webserver
- Description Data-Pool Values
- Description Protocol Implementation Conformance Statement PICS
- Description Modbus register
- Introduction to MP-Bus Technology