

Open/close ball valve, 2-way, Internal thread

- For potable water applications
- DVGW certified
- ACS certified
- WRAS certified
- Air-bubble tight

Type overview

Type	DN []	DN ["]	Rp ["]	kvs [m ³ /h]	PN []
EXT-R215-B3-PW	15	1/2	1/2	28	10
EXT-R220-B3-PW	20	3/4	3/4	42	10
EXT-R225-B3-PW	25	1	1	70	10
EXT-R232-B4-PW	32	1 1/4	1 1/4	80	10
EXT-R240-B4-PW	40	1 1/2	1 1/2	125	10
EXT-R250-B5-PW	50	2	2	179	10

Technical data

Functional data	Fluid	Potable water
	Potable water certificate	DVGW registration number: DW-6102CM0126 ACS registration number: 15 ACC LY 056 WRAS registration number: 1609315
	Fluid temperature	5...65°C
	Fluid temperature note	Occasional increases up to 90°C are permitted for a maximum period of 1 hour
	Permissible operating pressure ps	1000 kPa
	Close-off pressure Δps	1000 kPa
	Differential pressure Δpmax	1000 kPa
	Differential pressure note	200 kPa for low-noise operation
	Leakage rate	air-bubble tight, leakage rate A (EN 12266-1)
	Angle of rotation	90°
	Pipe connectors	Internal thread according to ISO 7-1
	Installation position	upright to horizontal (in relation to the stem)
	Servicing	maintenance-free
	Materials	Housing
Closing element		Chrome-plated brass (CW617N)
Stem		Nickel-plated brass (CW617N)
Stem seal		EPDM
Ball seat		PTFE

Safety notes



- The ball valve has to be exercised at least once a week, so that the quality of potable water as well as the functionality are not affected.
- The valve has been designed for use in stationary potable water systems and must not be used outside the specified field of application, especially in aircraft or in any other airborne means of transport.
- Only authorised specialists may carry out installation. All applicable legal or institutional installation regulations must be complied during installation.
- The valve does not contain any parts that can be replaced or repaired by the user.
- The valve may not be disposed of as household refuse. All locally valid regulations and requirements must be observed.
- When determining the flow rate characteristic of controlled devices, the recognised directives must be observed.

Product features

Mode of operation The open/close ball valve is adjusted by a rotary actuator. The rotary actuator is connected by an open/close signal. Open the ball valve counterclockwise and close it clockwise.

Installation notes



Notes • The ball valve is a regulating device. To fulfil this control task in the long term, the circuit must be kept free from particle debris (e.g. welding beads during installation work).

Recommended installation positions The ball valve can be installed upright to horizontal. The ball valve may not be installed in a hanging position, i.e. with the stem pointing downwards.

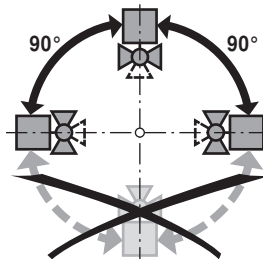

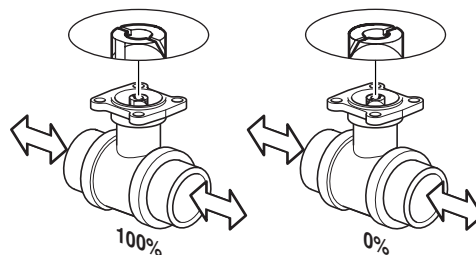

Servicing Ball valves and rotary actuators are maintenance-free. Before any service work on the final controlling device is carried out, it is essential to isolate the rotary actuator from the power supply (by unplugging the electrical cable if necessary). Any pumps in the part of the piping system concerned must also be switched off and the appropriate slide valves closed (allow all components to cool down first if necessary and always reduce the system pressure to ambient pressure level). The system must not be returned to service until the ball valve and the rotary actuator have been correctly reassembled in accordance with the instructions and the pipeline has been refilled by professionally trained personnel.

Flow direction Please also ensure that the balls are in the correct position (marking on the spindle).



Installation notes

Motorising EXT-R2..B..PW valves can be motorised with standard actuators A) or actuators with emergency control function B).

	A) 	B) 
EXT-R215-B3-PW	NR..A	NRF..A
EXT-R220-B3-PW	NR..A	NRF..A
EXT-R225-B3-PW	NR..A	NRF..A
EXT-R232-B4-PW	SR..A	SRF..A
EXT-R240-B4-PW	SR..A	SRF..A
EXT-R250-B5-PW	GR...-5	GRK...-5

A) Standard actuators
B) Fail-safe actuators

Dimensions / Weight

Dimensional drawings

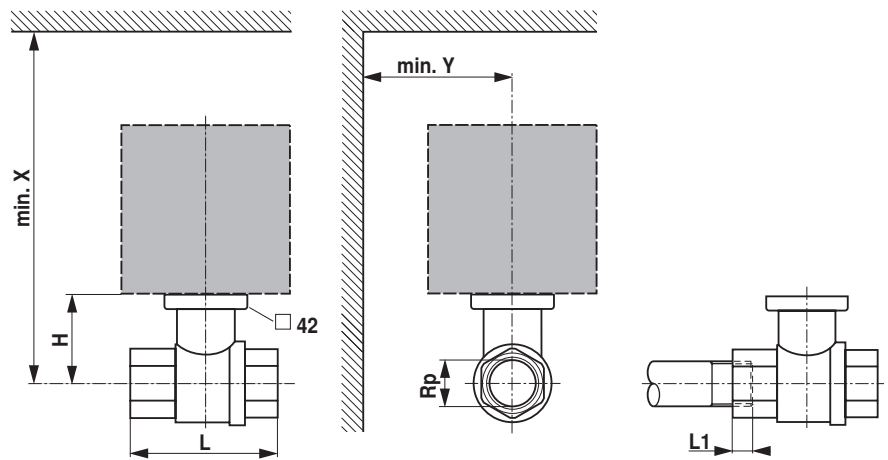

L1: Maximum screwing depth.

X/Y: Minimum distance with respect to the valve centre.

The actuator dimensions can be found on the respective actuator data sheet.

Type	DN []	Rp ["]	L [mm]	L1 [mm]	H [mm]	X [mm]	Y [mm]	Weight
EXT-R215-B3-PW	15	1/2	59	13	53	250	90	0.38 kg
EXT-R220-B3-PW	20	3/4	64	14	57	250	90	0.47 kg
EXT-R225-B3-PW	25	1	81	16	61	250	90	0.69 kg
EXT-R232-B4-PW	32	1 1/4	93	19	80	270	90	1.0 kg
EXT-R240-B4-PW	40	1 1/2	102	19	86	270	90	1.2 kg
EXT-R250-B5-PW	50	2	121	22	83	270	90	1.9 kg

Further documentation

- Data sheets for actuators
- Installation instructions for actuators and/or ball valves