

**Modulating globe valve actuator for 2-way and 3-way globe valves**

- Actuating force 1000 N
- Nominal voltage AC/DC 24 V
- Control modulating DC (0)2...10 V
- Nominal stroke 20 mm

**Technical data**

<b>Electrical data</b>	Nominal voltage	AC/DC 24 V
	Nominal voltage frequency	50/60 Hz
	Nominal voltage range	AC 19.2...28.8 V / DC 21.6...28.8 V
	Power consumption in operation	1.5 W
	Power consumption in rest position	0.5 W
	Power consumption for wire sizing	3 VA
	Connection supply / control	Terminals with cable 1 m, 4 x 0.75 mm <sup>2</sup> (Terminal 4 mm <sup>2</sup> )
	Parallel operation	Yes (note the performance data)
<b>Functional data</b>	Actuating force motor	1000 N
	Positioning signal Y	DC 0...10 V
	Positioning signal Y note	Input impedance 100 kΩ
	Operating range Y	DC 2...10 V
	Position feedback U	DC 2...10 V
	Position feedback U note	Max. 0.5 mA
	Position accuracy	5% absolute
	Manual override	With push-button, can be locked
	Nominal stroke	20 mm
	Actuating time motor	150 s / 20 mm
	Adaption setting range	manual (automatic on first power-up)
	Sound power level motor	45 dB(A)
	Position indication	Mechanically, 5...20 mm stroke
<b>Safety</b>	Protection class IEC/EN	III Safety extra-low voltage
	Protection class UL	UL Class 2 Supply
	Degree of protection IEC/EN	IP54
	Degree of protection NEMA/UL	NEMA 2, UL Enclosure Type 2
	EMC	CE according to 2014/30/EU
	Certification IEC/EN	IEC/EN 60730-1 and IEC/EN 60730-2-14
	Certification UL	cULus according to UL 60730-1A, UL 60730-2-14 and CAN/CSA E60730-1:02
	Mode of operation	Type 1
	Rated impulse voltage supply / control	0.8 kV
	Control pollution degree	3
Ambient temperature range	0...50 °C	
Non-operating temperature	-40...80 °C	
Ambient humidity	95% r.h., non-condensing	
Maintenance	Maintenance-free	
<b>Weight</b>	Weight	1.4 kg

**Safety notes**

- This device has been designed for use in stationary heating, ventilation and air conditioning systems and must not be used outside the specified field of application, especially in aircraft or in any other airborne means of transport.
- Only authorised specialists may carry out installation. All applicable legal or institutional installation regulations must be complied during installation.

**Safety notes**

- The switch for changing the direction of motion and so the closing point may be adjusted only by authorised specialists. The direction of motion is critical, particularly in connection with frost protection circuits.
- The device may only be opened at the manufacturer’s site. It does not contain any parts that can be replaced or repaired by the user.
- The device contains electrical and electronic components and must not be disposed of as household refuse. All locally valid regulations and requirements must be observed.

**Product features**

<b>Mode of operation</b>	The actuator is connected with a standard modulating signal of DC 0...10V and drives to the position defined by the positioning signal. The measuring voltage U serves for the electrical display of the actuator position 0...100% and as slave control signal for other actuators.
<b>Simple direct mounting</b>	Simple direct mounting on the globe valve by means of form-fit hollow clamping jaws. The actuator can be rotated by 360° on the valve neck.
<b>Manual override</b>	Manual override with push-button possible (the gear is disengaged for as long as the button is pressed or remains locked). The stroke can be adjusted by using a hexagon socket screw key (4 mm), which is inserted into the top of the actuator. The stroke spindle extends when the key is rotated clockwise.
<b>High functional reliability</b>	The actuator is overload protected, requires no limit switches and automatically stops when the end stop is reached.
<b>Combination valve/actuator</b>	Refer to the valve documentation for suitable valves, their permitted medium temperatures and closing pressures.
<b>Position indication</b>	The stroke is indicated mechanically on the bracket with tabs. The stroke range adjusts itself automatically during operation.
<b>Home position</b>	Factory setting: Actuator spindle is retracted. When valve-actuator combinations are shipped, the direction of motion is set in accordance with the closing point of the valve. The first time the supply voltage is switched on, i.e. at the time of commissioning, the actuator carries out an adaption, which is when the operating range and position feedback adjust themselves to the mechanical setting range. The actuator then moves into the position defined by the positioning signal.
<b>Direction of stroke switch</b>	When actuated, the direction of stroke switch changes the running direction in normal operation.
<b>Adaption and synchronisation</b>	An adaption can be triggered manually by pressing the “Adaption” button. Both mechanical end stops are detected during the adaption (entire setting range). The actuator then moves into the position defined by the positioning signal.

**Accessories**

	Description	Type
Electrical accessories	Auxiliary switch, 2 x SPDT, add-on, grey	S2A-H

Electrical installation



Notes

- Connection via safety isolating transformer.
- Parallel connection of other actuators possible. Observe the performance data.
- Direction of stroke switch factory setting: Actuator spindle retracted.

Wiring diagrams

AC/DC 24 V, modulating

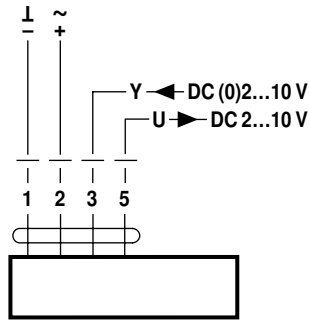

Cable colours:

- 1 = black
- 2 = red
- 3 = white
- 5 = orange

Override control (frost protection circuit)

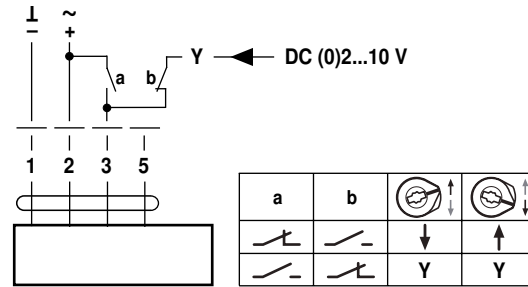

Operating controls and indicators

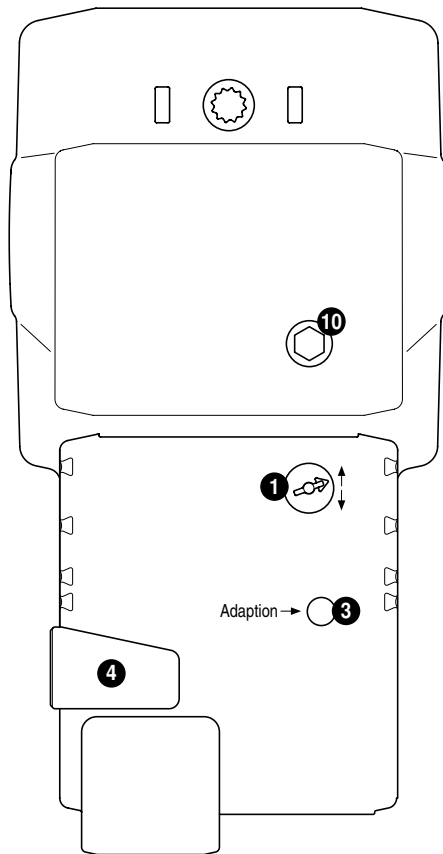

1 Direction of stroke switch

Switch over: Direction of stroke changes

3 Push-button and LED display yellow

Off: Standard mode  
 On: Adaptation process active  
 Press button: Triggers stroke adaptation, followed by standard mode

4 Gear disengagement button

Press button: Gear disengages, motor stops, manual override possible  
 Release button: Gear engages, synchronisation starts, followed by standard mode

10 Manual override

Clockwise: Actuator spindle extends  
 Counterclockwise: Actuator spindle retracts

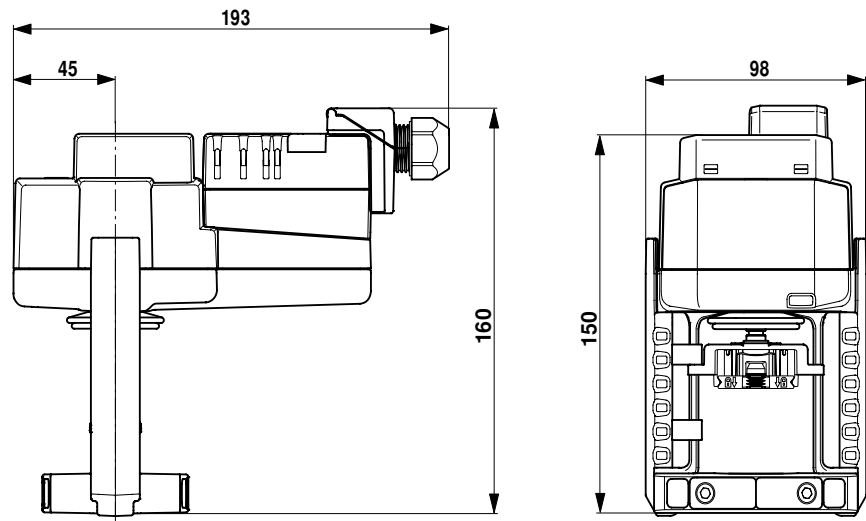
**Dimensions [mm]****Dimensional drawings****Further documentation**

- Overview Valve-actuator combinations
- Data sheets for globe valves
- Installation instructions for actuators and/or globe valves
- Notes for project planning 2-way and 3-way globe valves
- General notes for project planning