

Characterised control valves, 3-way,
with external thread

- For open and closed cold and warm water systems
- For modulating water-side control of air purification and heating systems
- Air bubble-tight (control path A - AB)

Type overview

Type	kvs [m ³ /h]	DN []	G ["]	ps [kPa]	n(gl) []	Sv min. []
R505K	0.25	10	3/4	1600	3.2	50
R506K	0.4	10	3/4	1600	3.2	50
R507K	0.63	10	3/4	1600	3.2	50
R508K	1	10	3/4	1600	3.2	50
R509	0.63	15	1	1600	3.2	50
R510	1	15	1	1600	3.2	50
R511	1.6	15	1	1600	3.2	50
R512	2.5	15	1	1600	3.2	50
R513	4	15	1	1600	3.9	100
R517	4	20	1 1/4	1600	3.9	100
R518	6.3	20	1 1/4	1600	3.9	100
R522	6.3	25	1 1/2	1600	3.9	100
R523	10	25	1 1/2	1600	3.9	100
R529	10	32	2	1600	3.9	100
R531	16	32	2	1600	3.9	100
R538	16	40	2 1/4	1600	3.9	100
R548	25	50	2 3/4	1600	3.9	100

Technical data

Functional data	Media	Cold and hot water, water with glycol up to max. 50% vol.
	Medium temperature	6°C...100°C
	Medium temperature note	-10°C with spindle heating (without R5..K, R529, R538 and R548)
	Closing pressure Δps	1400 kPa
	Differential pressure Δpmax	200 kPa
	Flow rate	Bypass B – AB: 70% of the kvs value
	Flow characteristic	Control path A – AB: equal percentage (VDI/VDE 2178), optimised in the opening range, Bypass B – AB: linear (VDI/VDE 2178)
	Leakage rate	Control path A – AB Leakage A, air bubble-tight (EN 12266-1), Bypass B – AB Leakage class I (EN 1349 and EN 60534-4) approx. 1...2% of the kvs value, with respect to the largest value within the DN
	Pipe connections	External thread according to ISO 228/1
	Angle of rotation	90° (operating range control path A – AB 15...90°, Bypass B – AB 15...70°)
	Maintenance	Maintenance-free
Materials	Valve	Forged brass, body nickel-plated
	Valve cone	Stainless steel
	Stem	Stainless steel
	Stem seal	O-ring EPDM
	Valve seat	PTFE, O-ring Viton

Safety notes



- The ball valve has been designed for use in stationary heating, ventilation and air conditioning systems and is not allowed to be used outside the specified field of application, especially not in aircraft or in any other airborne means of transport.
- Only authorised specialists may carry out installation. All applicable legal or institutional installation regulations must be complied with during installation.
- The ball valve does not contain any parts that can be replaced or repaired by the user.
- The ball valve may not be disposed of as household refuse. All locally valid regulations and requirements must be observed.
- When determining the flow rate characteristic of final controlling elements, the recognised directives must be observed.

Product features

- Principle of operation** The characterised control valve is operated by a rotary actuator. The rotary actuator is controlled by a commercially available modulating or 3-point control system and moves the ball of the valve – the throttling device – to the position dictated by the positioning signal. Open the characterised control valve counterclockwise and close it clockwise.
- Flow characteristic** Equal percentage flow control is ensured by the integrated characterising disk.

Accessories

	Description	Type
Electrical accessories	Spindle heating DN 15-50 (45 W)	ZR24-1
Mechanical accessories	Pipe connector to ball valves DN 10 Rp 3/8"	ZR4510
	Pipe connector to ball valves DN 15 Rp 1/2"	ZR4515
	Pipe connector to ball valves DN 20 Rp 3/4"	ZR4520
	Pipe connector to ball valves DN 25 Rp 1"	ZR4525
	Pipe connector to ball valves DN 32 Rp 1 1/4"	ZR4532
	Pipe connector to ball valves DN 40 Rp 1 1/2"	ZR4540
	Pipe connector to ball valves DN 50 Rp 2"	ZR4550

Installation notes

- Recommended installation positions** The ball valve can be installed upright to horizontal. The ball valve may not be installed in a hanging position, i.e. with the stem pointing downwards.

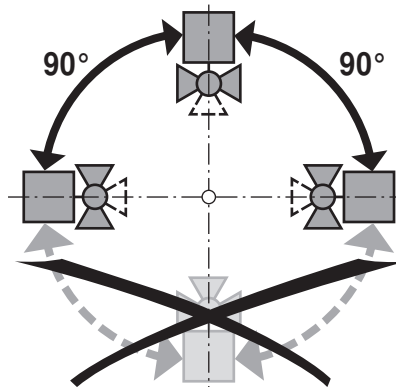

- Water quality requirements** The water quality requirements specified in VDI 2035 must be adhered to. Ball valves are regulating devices. The use of dirt filters is recommended in order to prolong their service life for performing control tasks.

Installation notes

- Maintenance** Ball valves and rotary actuators are maintenance-free. Before any kind of service work is carried out on the actuator, it is essential to isolate the rotary actuator from the power supply (by disconnecting the electrical cable). Any pumps in the part of the piping system concerned must also be switched off and the appropriate slide valves closed (allow everything to cool down first if necessary and reduce the system pressure to ambient pressure level). The system must not be returned to service until the ball valve and the rotary actuator have been properly reassembled in accordance with the instructions and the pipelines have been refilled in the proper manner.
- Flow direction** The direction of flow, specified by an arrow on the housing, is to be complied with, since otherwise the ball valve could become damaged. Please ensure that the ball is in the correct position (marking on the stem).

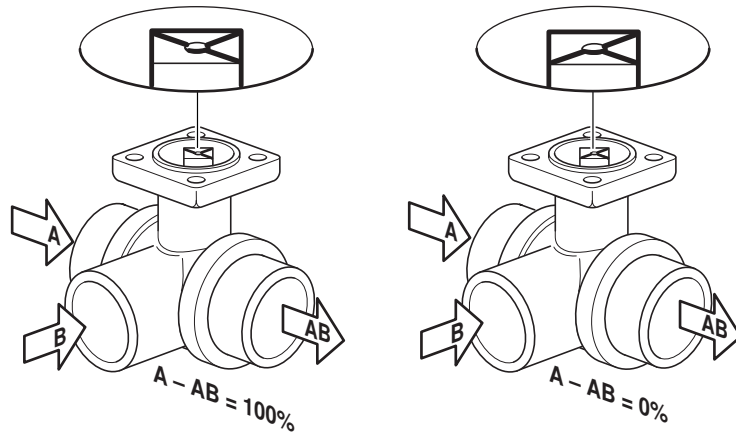

Dimensions [mm] / weight

Dimensional drawings

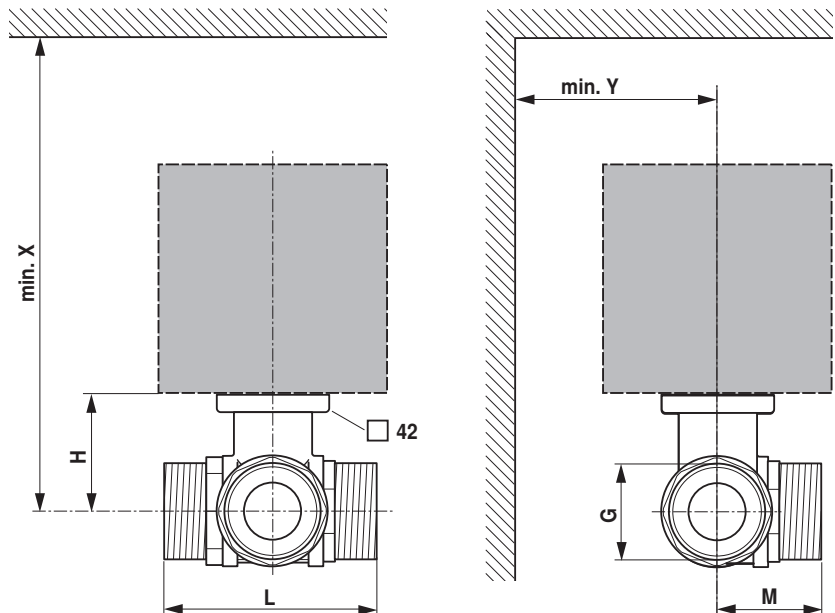

X/Y: Minimum distance with respect to the valve centre.
The actuator dimensions can be found on the respective actuator data sheet.

Type	DN []	G ["]	L [mm]	H [mm]	X [mm]	Y [mm]	Weight approx. [kg]
R505K	10	3/4	69	31.5	220	90	0.4
R506K	10	3/4	69	31.5	220	90	0.4
R507K	10	3/4	69	31.5	220	90	0.4
R508K	10	3/4	69	31.5	220	90	0.4
R509	15	1	74	44	220	90	0.7
R510	15	1	74	44	220	90	0.7

Dimensions [mm] / weight

Type	DN []	G [""]	L [mm]	H [mm]	X [mm]	Y [mm]	Weight approx. [kg]
R511	15	1	74	44	220	90	0.7
R512	15	1	74	44	220	90	0.7
R513	15	1	74	44	220	90	0.7
R517	20	1 1/4	85.5	46	220	90	1
R518	20	1 1/4	85.5	46	220	90	1
R522	25	1 1/2	84.5	46	220	90	1.1
R523	25	1 1/2	84.5	46	220	90	1.1
R529	32	2	103.5	46	220	90	1.7
R531	32	2	107.5	50.5	230	90	1.8
R538	40	2 1/4	114.5	50.5	230	90	2.3
R548	50	2 3/4	131.5	56	240	90	3.8

Further documentation

- Overview Valve-actuator combinations
- Data sheets for actuators
- Installation instructions for actuators and/or ball valves
- General notes for project planning

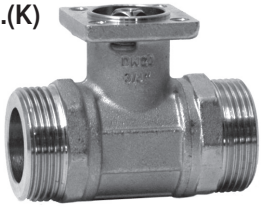

R4..(K)

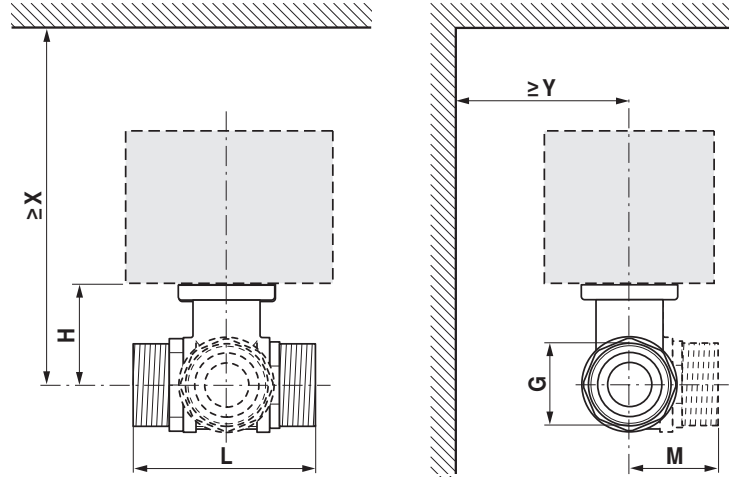
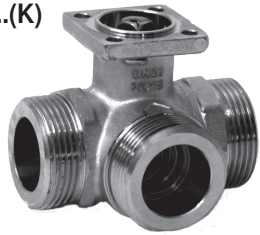

R5..(K)



71604-00001.A

		DN	G	mm			80 °C		100 °C						100 °C									
							KR..		TR..		LR..A		NR..A		SR..A		TRF..		LRF..		NRF..A		SRF..A	
		mm	”	L	H	M	X	Y	X	Y	X	Y	X	Y	X	Y	X	Y	X	Y	X	Y	X	Y
R405K ... R409K	R505K ... R508K	10	3/4"	69	31.5	34	138	75	173	75	187	75	218	80	218	80	178	60	188	90	188	90	188	90
R409 ... R415	R509 ... R515	15	1"	74	44	37	150	75	185	75	195	75	230	80	230	80	190	60	200	90	220	90	220	90
R417 ... R420	R517 ... R520	20	1 1/4"	85.5	46	42.5					200	75	235	80	235	80			205	90	225	90	225	90
R422 ... R425	R522 ... R525	25	1 1/2"	84.5	46	47.5					200	75	235	80	235	80			205	90	225	90	225	90
R429 ... R430		32	2"	97.5	46						200	75	235	80	235	80			205	90	225	90	225	90
	R529 ... R530	32	2"	103.5	46	56					200	75	235	80	235	80			205	90	225	90	225	90
R431 ... R432		32	2"	102	50.5								240	80	240	80					230	90	230	90
	R531 ... R532	32	2"	107.5	50.5	56							240	80	240	80					230	90	230	90
R438 ... R440		40	2 1/4"	103.5	50.5								240	80	240	80					230	90	230	90
	R538 ... R540	40	2 1/4"	114.5	50.5	60.5							240	80	240	80					230	90	230	90
R448 ... R450		50	2 3/4"	115.5	56										245	80							235	90
	R548 ... R550	50	2 3/4"	131.5	56	71.5									245	80							235	90

