

**Change-over ball valve, 3-way,
External thread**

- For open and closed cold and warm water systems
- For switching functions and 2-point controls on the water side of air handling units and heating systems
- Suitable for potable water
- Air bubble-tight (control path A - AB)

Type overview

Type	DN []	G [“]	kvs [m ³ /h]	PN []
R515	15	1	8.6	16
R520	20	1 1/4	21	16
R525	25	1 1/2	26	16
R530	32	2	16	16
R532	32	2	32	16
R540	40	2 1/4	32	16
R550	50	2 3/4	49	16

Technical data

Functional data	Media	
		Cold and hot water, potable water, water with glycol up to max. 50% vol.
	Medium temperature	6...100°C
	Medium temperature note	-10°C with stem heating (without R530, R540 and R550) The allowed media temperature can be limited, depending on the type of actuator. Limitations can be found in the respective data sheets of the actuators.
	Permissible pressure ps	1600 kPa
	Closing pressure Δps	1400 kPa
	Differential pressure Δpmax	400 kPa
	Differential pressure note	200 kPa for low-noise operation
	Flow rate	Bypass B – AB: Approx. 50% of kvs value
	Leakage rate	Port A - AB: Leakage rate A, air-bubble-tight (EN 12266-1); Bypass B - AB: Leakage class I Leakage class I max. 1% of the kvs value
	Pipe connector	External thread according to ISO 228-1
	Angle of rotation	90°
	Installation position	Upright to horizontal (in relation to the stem)
	Maintenance	Maintenance-free
Materials	Housing	Brass body nickel-plated
	Closing element	Stainless steel
	Stem	Stainless steel
	Stem seal	O-ring EPDM
	Ball seat	PTFE, O-ring Viton
	Grease	Klübersynth VR 69-252N (drinking water grade)

Safety notes

- The valve has been designed for use in stationary heating, ventilation and air-conditioning systems and must not be used outside the specified field of application, especially in aircraft or in any other airborne means of transport.
- Only authorised specialists may carry out installation. All applicable legal or institutional installation regulations must be complied during installation.
- The valve does not contain any parts that can be replaced or repaired by the user.

Safety notes

- The valve may not be disposed of as household refuse. All locally valid regulations and requirements must be observed.
- When determining the flow rate characteristic of controlled devices, the recognised directives must be observed.

Product features

Mode of operation The open-close ball valve is adjusted by a rotary actuator. The rotary actuator is connected by an open-close signal. Open the ball valve counterclockwise and close it clockwise.

Accessories

	Description	Type
Electrical accessories	Spindle heating DN 15-50 (5W)	ZR24-2
	Description	Type
Mechanical accessories	Pipe connector to ball valve DN 15 Rp 1/2"	ZR4515
	Pipe connector to ball valve DN 20 Rp 3/4"	ZR4520
	Pipe connector to ball valve DN 25 Rp 1"	ZR4525
	Pipe connector to ball valve DN 32 Rp 1 1/4"	ZR4532
	Pipe connector to ball valve DN 40 Rp 1 1/2"	ZR4540
	Pipe connector to ball valve DN 50 Rp 2"	ZR4550

Installation notes

Recommended installation positions The ball valve can be installed upright to horizontal. The ball valve may not be installed in a hanging position, i.e. with the stem pointing downwards.

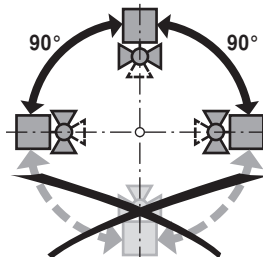

Water quality requirements The water quality requirements specified in VDI 2035 must be adhered to. Belimo valves are regulating devices. For the valves to function correctly in the long term, they must be kept free from particle debris (e.g. welding beads during installation work). The installation of suitable strainer is recommended.

Maintenance Ball valves and rotary actuators are maintenance-free. In the event of any service work on the final controlling device, it is essential to isolate the rotary actuator from the power supply (by unplugging the electrical cable). Any pumps in the part of the piping system concerned must also be switched off and the appropriate slide valves closed (allow everything to cool down first if necessary and reduce the system pressure to ambient pressure level). The system must not be returned to service until the ball valve and the rotary actuator have been properly reassembled in accordance with the instructions and the pipeline has been refilled in the proper manner.

Installation notes

Flow direction The direction of flow, specified by an arrow on the housing, is to be complied with, since otherwise the ball valve could become damaged. Please ensure that the ball is in the correct position (marking on the spindle).

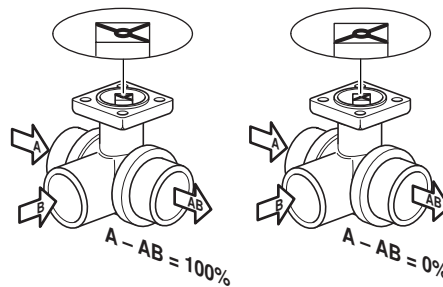

Dimensions / Weight

Dimensional drawings

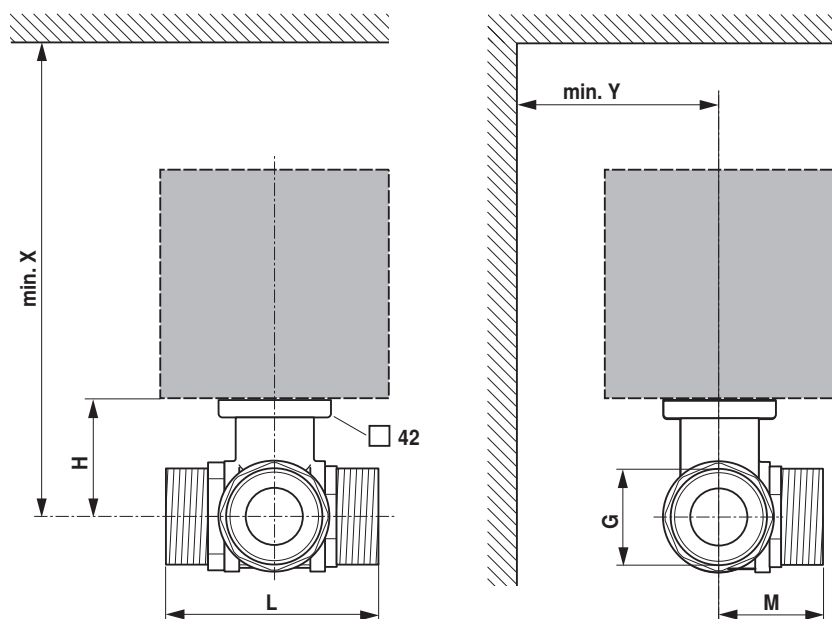

X/Y: Minimum distance with respect to the valve centre.
The actuator dimensions can be found on the respective actuator data sheet.

Type	DN []	G [“]	L [mm]	M [mm]	H [mm]	X [mm]	Y [mm]	Weight [kg]
R515	15	1	74	39	44	220	90	0.60
R520	20	1 1/4	85.5	41.5	46	220	90	0.92
R525	25	1 1/2	84.5	45	46	220	90	1.1
R530	32	2	103.5	55.5	46	220	90	1.7
R532	32	2	107.5	55.5	50.5	230	90	1.8
R540	40	2 1/4	114.5	56	50.5	230	90	2.2
R550	50	2 3/4	131.5	68	56	240	90	3.8

Further documentation

- Overview Valve-actuator combinations
- Data sheets for actuators
- Installation instructions for actuators and/or ball valves
- General notes for project planning