

Communicative globe valve actuator for 2-way and 3-way globe valves

- Actuating force 1500 N
- Nominal voltage AC/DC 24 V
- Control modulating, communicative 2...10 V variable
- Stroke 50 mm
- Conversion of sensor signals
- Communication via Belimo MP-Bus

Technical data

Electrical data	Nominal voltage	AC/DC 24 V
	Nominal voltage frequency	50/60 Hz
	Nominal voltage range	AC 19.2...28.8 V / DC 21.6...28.8 V
	Power consumption in operation	3.5 W
	Power consumption in rest position	1.5 W
	Power consumption for wire sizing	5 VA
	Connection supply / control	Terminals 4 mm ² (cable Ø4...10 mm)
	Parallel operation	Yes (note the performance data)
Functional data	Actuating force motor	1500 N
	Communicative control	MP-Bus
	Operating range Y	2...10 V
	Input Impedance	100 kΩ
	Options positioning signal	Open/close 3-point (AC only) Modulating (DC 0...32 V)
	Operating range Y variable	Start point 0.5...30 V End point 2.5...32 V
	Position feedback U	2...10 V
	Position feedback U note	Max. 0.5 mA
	Position feedback U variable	Start point 0.5...8 V End point 2.5...10 V
	Position accuracy	±5%
	Manual override	with push-button, can be locked
	Stroke	50 mm
	Running time motor	150 s / 50 mm
	Running time motor variable	90...150 s
	Adaptation setting range	manual (automatic on first power-up)
	Adaptation setting range variable	No action Adaptation when switched on Adaptation after pushing the gear disengagement button
	Override control	MAX (maximum position) = 100% MIN (minimum position) = 0% ZS (intermediate position, AC only) = 50%
	Override control variable	MAX = (MIN + 33%)...100% MIN = 0%...(MAX - 33%) ZS = MIN...MAX
Sound power level, motor	55 dB(A)	
Position indication	Mechanically, 5...50 mm stroke	
Safety	Protection class IEC/EN	III Safety Extra-Low Voltage (SELV)
	Protection class UL	UL Class 2 Supply
	Degree of protection IEC/EN	IP54
	Degree of protection NEMA/UL	NEMA 2
	Enclosure	UL Enclosure Type 2
	EMC	CE according to 2014/30/EU
	Certification IEC/EN	IEC/EN 60730-1 and IEC/EN 60730-2-14
Certification UL	cULus according to UL60730-1A, UL60730-2-14 and CAN/CSA E60730-1:02	

Technical data

Safety	Certification UL note	The UL marking on the actuator depends on the production site, the device is UL-compliant in any case
	Mode of operation	Type 1
	Rated impulse voltage supply / control	0.8 kV
	Control pollution degree	3
	Ambient temperature	0...50°C
	Storage temperature	-40...80°C
	Ambient humidity	Max. 95% r.H., non-condensing
	Servicing	maintenance-free
Weight	Weight	5.5 kg

Safety notes



- This device has been designed for use in stationary heating, ventilation and air-conditioning systems and must not be used outside the specified field of application, especially in aircraft or in any other airborne means of transport.
- Outdoor application: only possible in case that no (sea) water, snow, ice, insolation or aggressive gases interfere directly with the actuator and that is ensured that the ambient conditions remain at any time within the thresholds according to the data sheet.
- Only authorised specialists may carry out installation. All applicable legal or institutional installation regulations must be complied during installation.
- The switch for changing the direction of motion and so the closing point may be adjusted only by authorised specialists. The direction of motion is critical, particularly in connection with frost protection circuits.
- The device may only be opened at the manufacturer's site. It does not contain any parts that can be replaced or repaired by the user.
- The device contains electrical and electronic components and must not be disposed of as household refuse. All locally valid regulations and requirements must be observed.

Product features

Mode of operation	<p>Conventional operation: The actuator is connected with a standard modulating signal of 0...10 V and drives to the position defined by the positioning signal. The measuring voltage U serves for the electrical display of the actuator position 0.5...100% and as slave control signal for other actuators.</p> <p>Operation on Bus: The actuator receives its digital positioning signal from the higher level controller via the MP-Bus and drives to the position defined. Connection U serves as communication interface and does not supply an analogue measuring voltage.</p>
Converter for sensors	Connection option for a sensor (passive or active sensor or switching contact). The MP actuator serves as an analogue/digital converter for the transmission of the sensor signal via MP-Bus to the higher level system.
Parametrisable actuators	The factory settings cover the most common applications. Single parameters can be modified with the Belimo Service Tools MFT-P or ZTH EU.
Installation on third-party valves	The retrofit actuators for installation on a wide range of valves from various manufacturers are comprised of an actuator, universal valve neck adapter and universal valve stem adapter. Adapt the valve neck and valve stem to begin with, then attach the retrofit actuator to the valve neck adapter, connect to the valve and start up. The valve neck adapter/actuator can be rotated through 360° on the valve neck, provided it is permitted by the size of the installed valve.
Installation on Belimo valves	Use standard actuators from Belimo for mounting on Belimo globe valves.
Manual override	<p>Manual override with push-button possible (the gear is disengaged for as long as the button is pressed or remains locked).</p> <p>The stroke can be adjusted by using a hexagon socket screw key (5 mm), which is inserted into the top of the actuator. The stroke shaft extends when the key is rotated clockwise.</p>

Product features

High functional reliability	The actuator is overload protected, requires no limit switches and automatically stops when the end stop is reached.
Position indication	The stroke is indicated mechanically on the bracket with tabs. The stroke range adjusts itself automatically during operation.
Home position	Factory setting: Actuator spindle is retracted. The first time the supply voltage is switched on, i.e. at the time of commissioning, the actuator carries out an adaption, which is when the operating range and position feedback adjust themselves to the mechanical setting range. The actuator then moves into the position defined by the positioning signal.
Setting direction of stroke	When actuated, the stroke direction switch changes the running direction in normal operation.
Adaption and synchronisation	An adaption can be triggered manually by pressing the "Adaption" button or with the PC-Tool. Both mechanical end stops are detected during the adaption (entire setting range). Automatic synchronisation after pressing the gearbox disengagement button is configured. The synchronisation is in the home position (0%). The actuator then moves into the position defined by the positioning signal. A range of settings can be adapted using the PC-Tool (see MFT-P documentation)

Accessories

	Description	Type
Gateways	Gateway MP zu BACnet MS/TP	UK24BAC
	Gateway MP to Modbus RTU	UK24MOD
	Gateway MP to LonWorks	UK24LON
	Gateway MP to KNX	UK24EIB
Electrical accessories	Description	Type
	Auxiliary switch 2 x SPDT add-on	S2A-H
	Connection cable 5 m, A: RJ11 6/4 ZTH EU, B: 6-pin service socket for Belimo device	ZK1-GEN
	Connection cable 5 m, A: RJ11 6/4 ZTH EU, B: free wire end for connection to MP/PP terminal	ZK2-GEN
	MP-Bus power supply for MP actuators	ZN230-24MP
	Connecting board MP-Bus for wiring boxes EXT-WR-FP..-MP	ZFP2-MP
Service Tools	Description	Type
	Service Tool, with ZIP-USB function	ZTH EU
	Belimo PC-Tool, Software for adjustments and diagnostics	MFT-P
	Adapter for Service-Tool ZTH	MFT-C

Electrical installation



Notes

- Connection via safety isolating transformer.
- Parallel connection of other actuators possible. Observe the performance data.
- Direction of stroke switch factory setting: Actuator spindle retracted (▲).

Electrical installation

Wiring diagrams

AC/DC 24 V, modulating

Operation on the MP-Bus

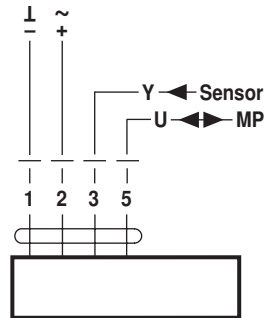
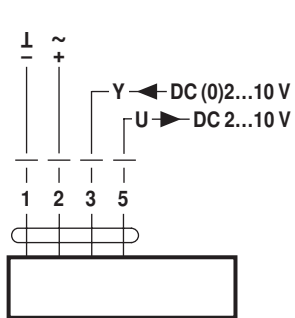

Functions

Functions when operated on MP-Bus

Connection on the MP-Bus

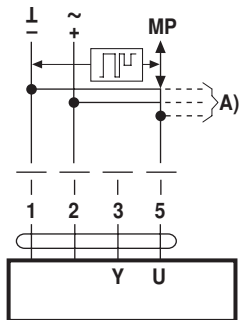

A) more actuators and sensors (max.8)

MP-Bus Network topology

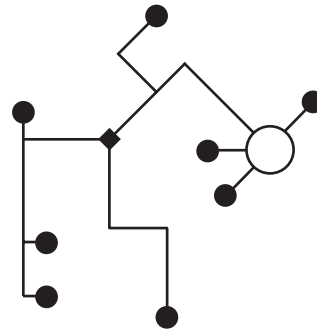

There are no restrictions for the network topology (star, ring, tree or mixed forms are permitted). Supply and communication in one and the same 3-wire cable

- no shielding or twisting necessary
- no terminating resistors required

Connection of active sensors

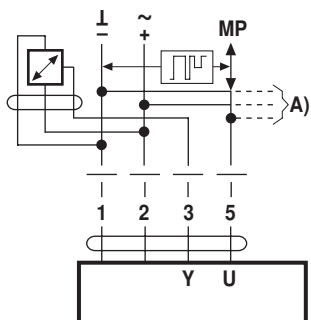

A) more actuators and sensors (max.8)

- Supply AC/DC 24 V
- Output signal DC 0...10 V (max. DC 0...32 V)
- Resolution 30 mV

Connection of external switching contact

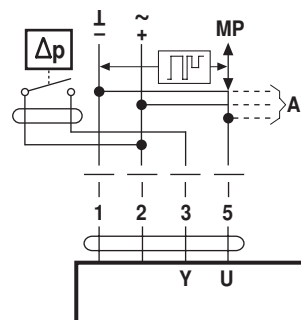

A) more actuators and sensors (max.8)

- Switching current 16 mA @ 24 V
- Start point of the operating range must be parameterised on the MP actuator as $\geq 0.5 V$

Connection of passive sensors

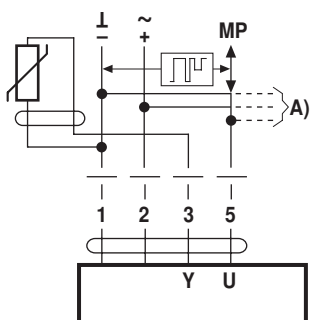

Ni1000	-28...+98°C	850...1600 Ω^2)
PT1000	-35...+155°C	850...1600 Ω^2)
NTC	-10...+160°C 1)	200 Ω ...60 k Ω^2)

A) more actuators and sensors (max.8)

- 1) Depending on the type
- 2) Resolution 1 Ohm

Functions

Functions with basic values (conventional mode)

Override control with AC 24 V with relay contacts

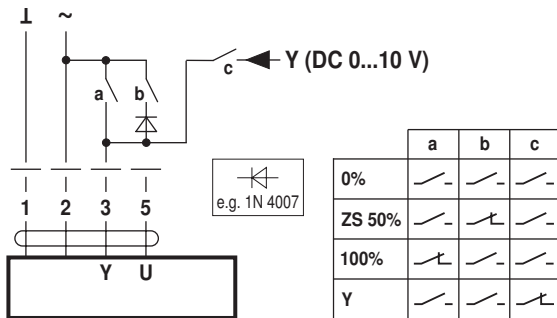

Override control with AC 24 V with rotary switch

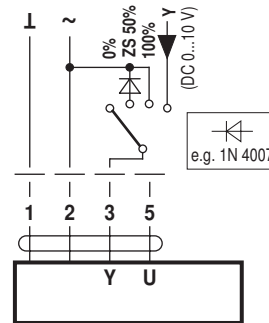

Control remotely 0...100% with positioner SG..

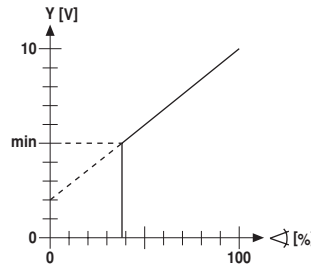
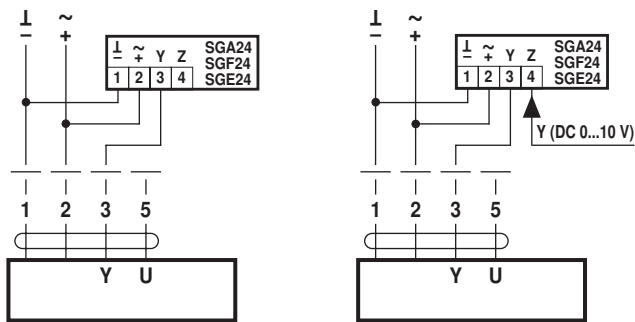

Follow-up control (position-dependent)

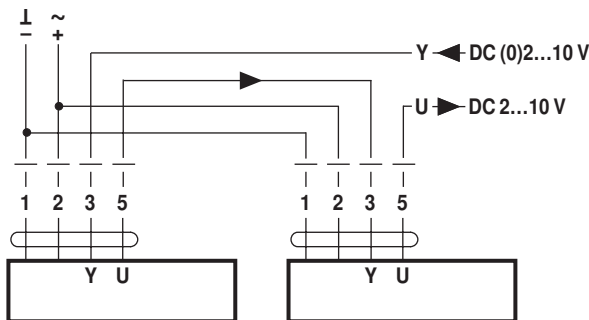

Control with 4...20 mA via external resistor

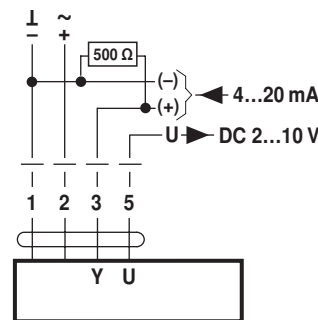

Caution:
The operating range must be set to DC 2...10 V.
The 500 Ω resistor converts the 4...20 mA current signal to a voltage signal DC 2...10 V

Functional check

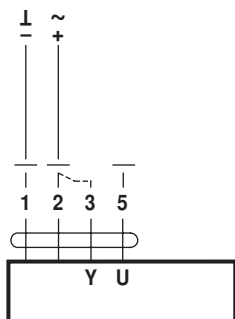

Procedure

1. Apply 24 V to connection 1 and 2
2. Disconnect connection 3:
 - with upwards direction of motion: closing point at top
 - with downwards direction of motion: closing point at bottom
3. Short circuit connections 2 and 3:
 - Actuator runs in the opposite direction

Functions

Functions for devices with specific parameters (Parametrisation necessary)

Override control and limiting with AC 24 V with relay contacts

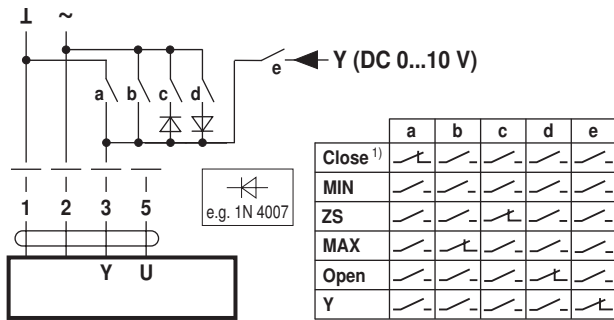

Override control and limiting with AC 24 V with rotary switch

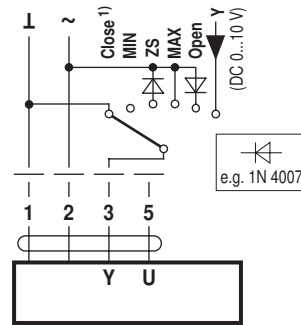

1) **Caution:** This function is only guaranteed if the start point of the operating range is defined as min. 0.5 V.

Control open/close

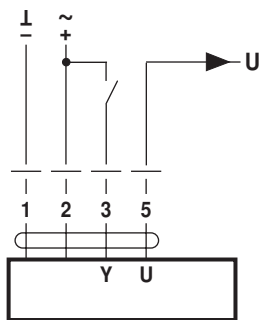

Control 3-point

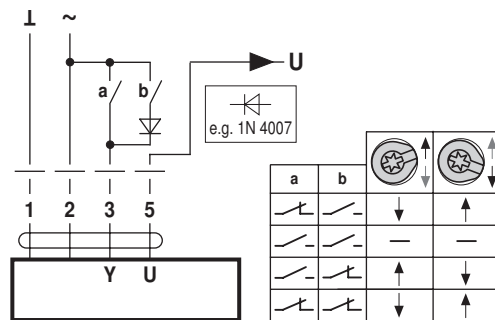

Operating controls and indicators

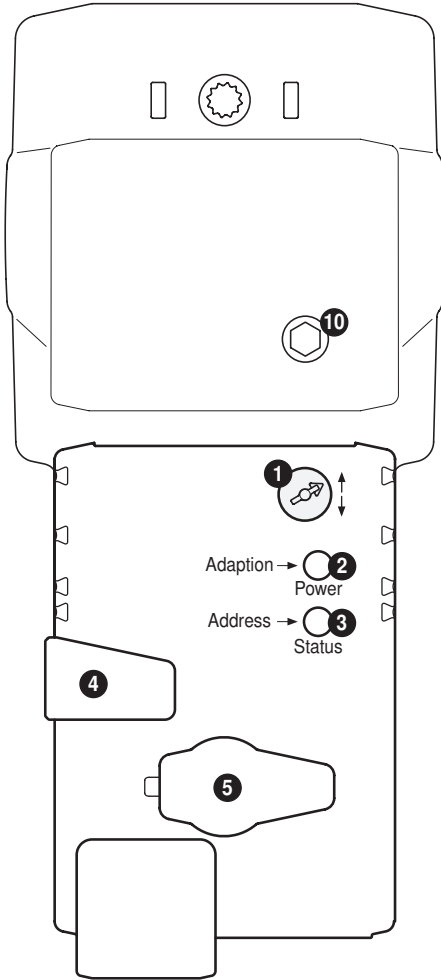

- 1 Direction of stroke switch**
Switch over: Direction of stroke changes
- 2 Push-button and LED display green**
Off: No power supply or malfunction
On: In operation
Press button: Triggers stroke adaptation, followed by standard mode
- 3 Push-button and LED display yellow**
Off: Standard mode
Flickering: MP communication active
On: Adaptation process active
Flashing: Request for addressing from MP master
Press button: Confirmation of the addressing
- 4 Gear disengagement button**
Press button: Gear disengages, motor stops, manual override possible
Release button: Gear engages, standard mode
- 5 Service plug**
For connecting parameterisation and service tools
- 10 Manual override**
Clockwise: Actuator spindle extends
Counterclockwise: Actuator spindle retracts

Check power supply connection

- 2** Off and **3** On Possible wiring error in power supply

Service

Service Tools connection The actuator can be parametrised by ZTH EU via the service socket. For an extended parameterisation the PC tool can be connected.

Connection ZTH EU / PC-Tool

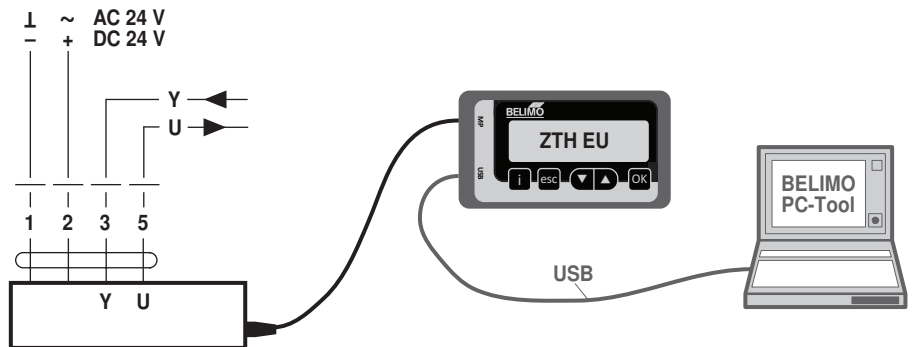

Dimensions [mm]

Dimensional drawings

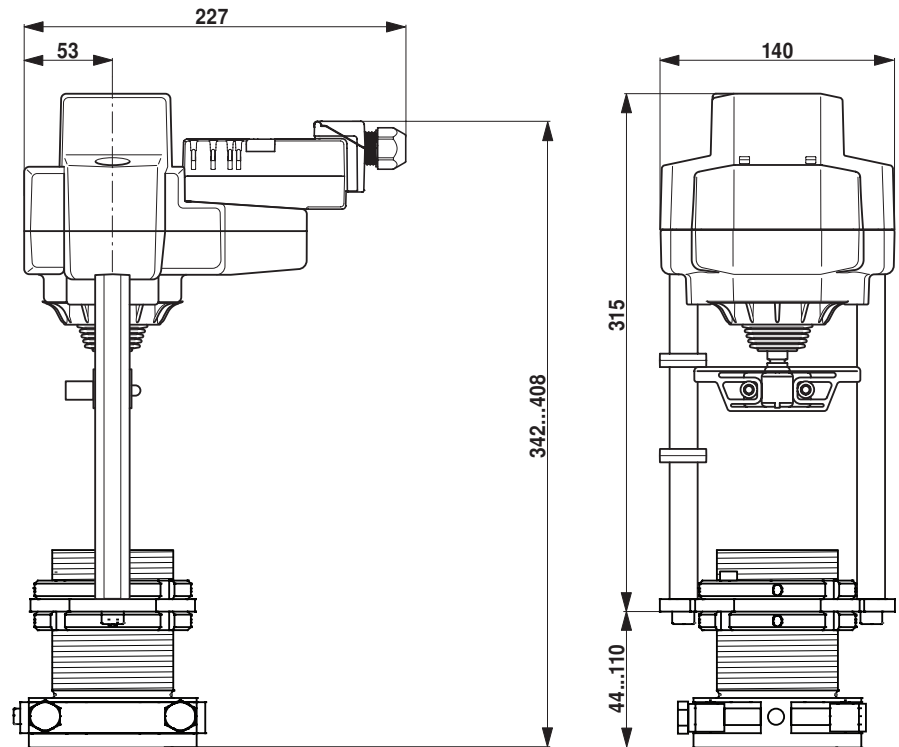

Further documentation

- Tool connections
- Introduction to MP-Bus Technology
- Overview MP Cooperation Partners
- Data sheets for globe valves
- Installation instructions for actuators